

MAGNETIC DRIVEN CENTRIFUGAL PUMPS

Series EUROLINE

M6.1

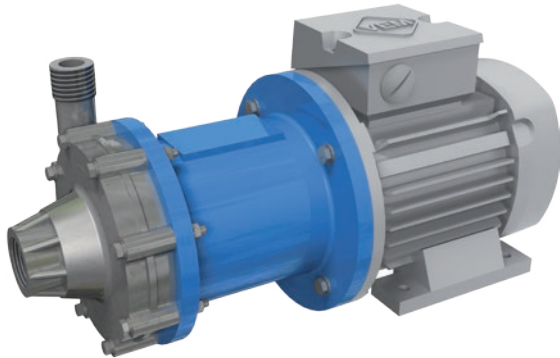

TECHNICAL DATA

Nominal speed:	2900 1/min
Capacity flow, max.:	6 m ³ /h
Discharge head, max.:	8 mWs
Design pressure, max.:	16 bar
Design temperature, max.:	120°C
Density, max.:	1,9 kg/dm ³
Viscosity, max.:	200 cP

APPLICATIONS

Series M / EUROLINE Magnetic Driven Centrifugal Pumps are used especially for a safe handling of corrosive liquids, acids, lyes and solvents. Proven applications e.g. the use as filterpumps in plating industry, such as recirculating pumps in chemical industries and Plants, as well as in food-, pharmaceutical industry and biotechnics.

CONNECTIONS

Suction side: G1" female, Flanged DN25
Discharge side: G 3/4" male, Flanged DN20

MATERIALS

Housing: AISI316L
O-Ring: EPDM, FKM, FEP
Bushing: PTFE C25%, Carbon-Graphite, SiC
Shaft: SiC, Hastelloy C, AISI316
Thrust bearing: PTFE C25%, Carbon-Graphite

DESIGN FEATURES

- Centrifugal Pump
- Closed Impeller, capsulated
- Leak-free
- Magnetic driven
- NdFeB or CoSm permanent magnets
- Closed coupled
- Normal suction
- Metallic
- Maintenance free
- Only a few wear parts
- Pump execution acc. to Ex II2G cbk T3-5

PRODUCT DESCRIPTION

MARCH Magnetic Driven Centrifugal Pumps are designed to work completely without mechanical shaft sealing. The motor power is transmitted by a frictional connection through strong drive magnets to the hydraulic part. MARCH Magnetic Driven Centrifugal Pumps guarantee highest quality standards, economic efficiency and reliability in liquid transfer of aggressive, toxic and environmental threatening liquids.

The pumps are built with stainless steel housing parts and in a closed coupled block design as standard. The modular construction allows a quick exchange of the wetted parts within a few minutes and without special tools. The friction bearing lubrication and cooling is done by the pumped liquid. As the pumps work maintenance-free, an operation without liquid (dry running) has to be avoided. European IEC standard motors according to IEC / EN 600340 are assembled on all Series M / EUROLINE Pumps. Explosion proof models are available upon request. All Series M / EUROLINE pumps can be supplied with BSP/NPT threads, flanges, hose connection or union fitting. The operative limits, especially min. and max. flow rates and the required net positive suction head (NPSH) are important for the trouble-free operation of the pump.



Q (U.S. gpm)

0 5 10 15 20 25

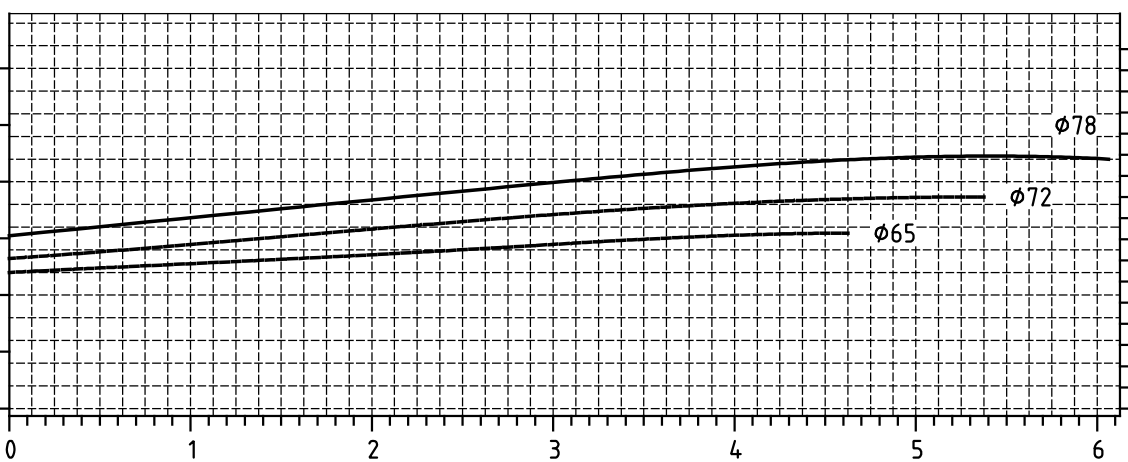
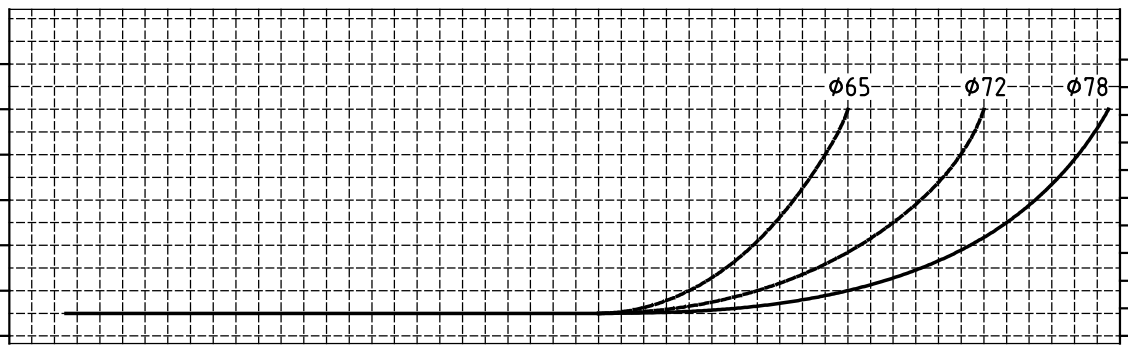
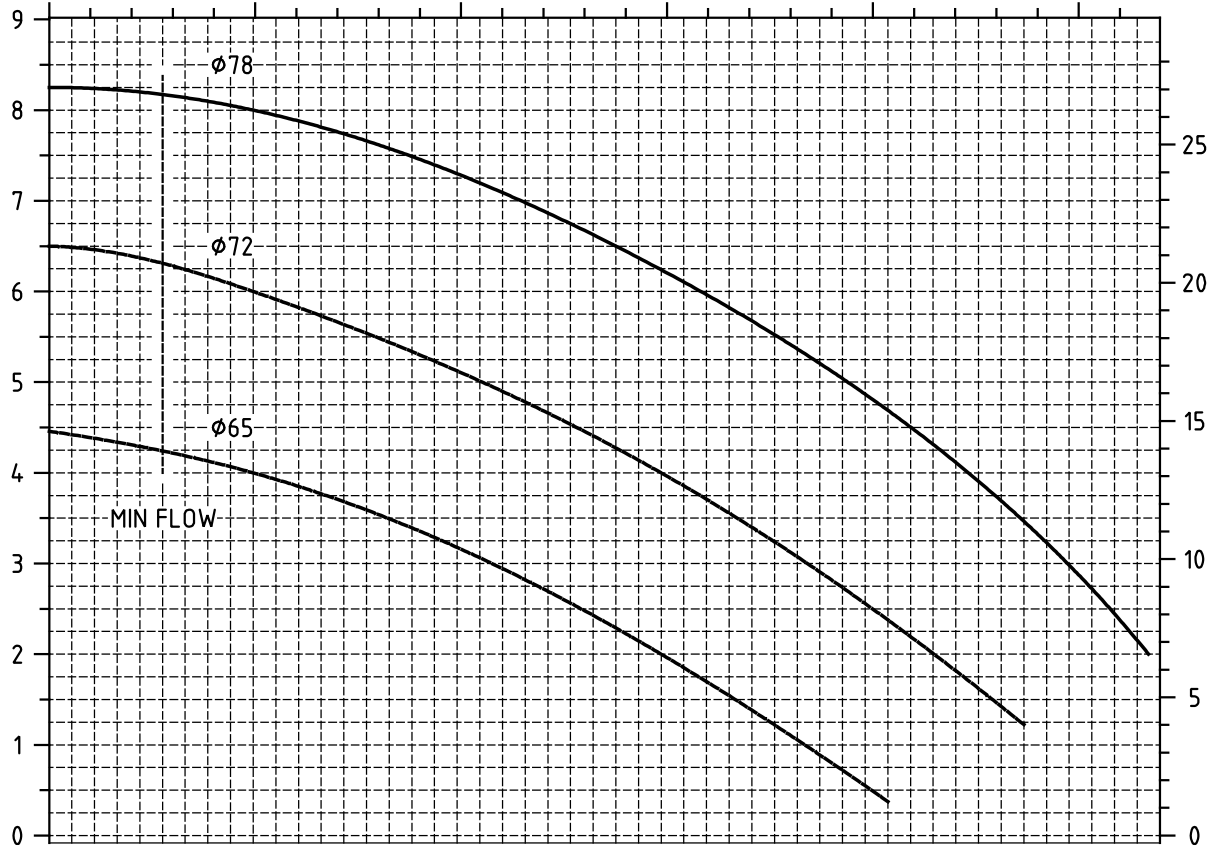

Q (m³/h)

0 1 2 3 4 5 6



MARCH PUMPEN GmbH & Co.KG
 Rathenaustraße 2
 D-35394 Gießen
 www.march-pumpen.com
 info@march-pumpen.com

Baureihe / Series:	EUROLINE
Typ / Type:	M6.1 AISI316
Motor:	0,37 - 0,55 kW - 2900 1/min

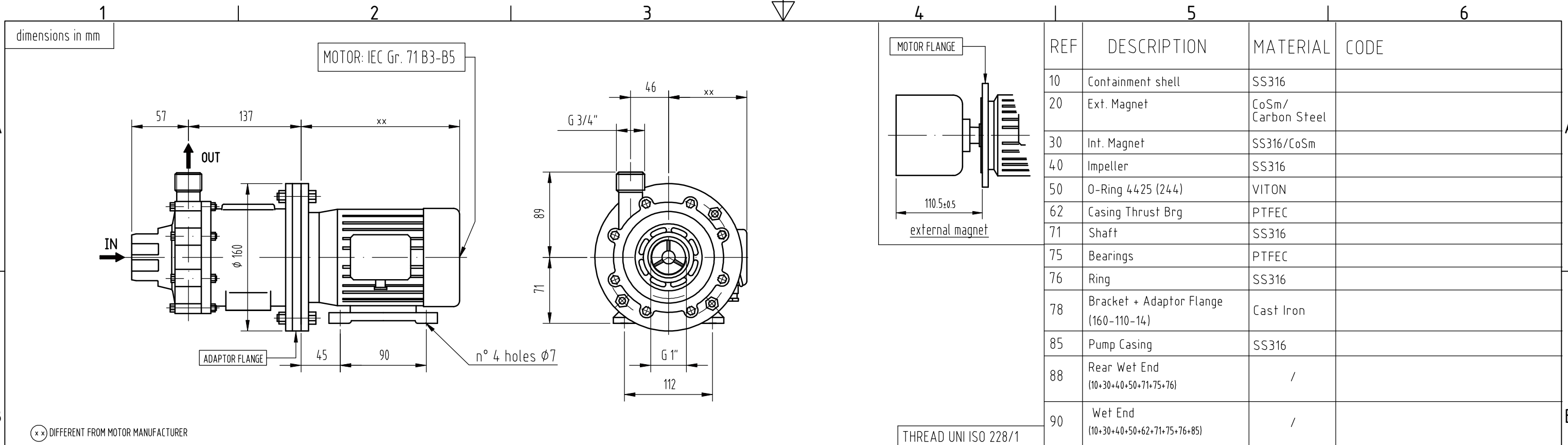

(xx) DIFFERENT FROM MOTOR MANUFACTURER

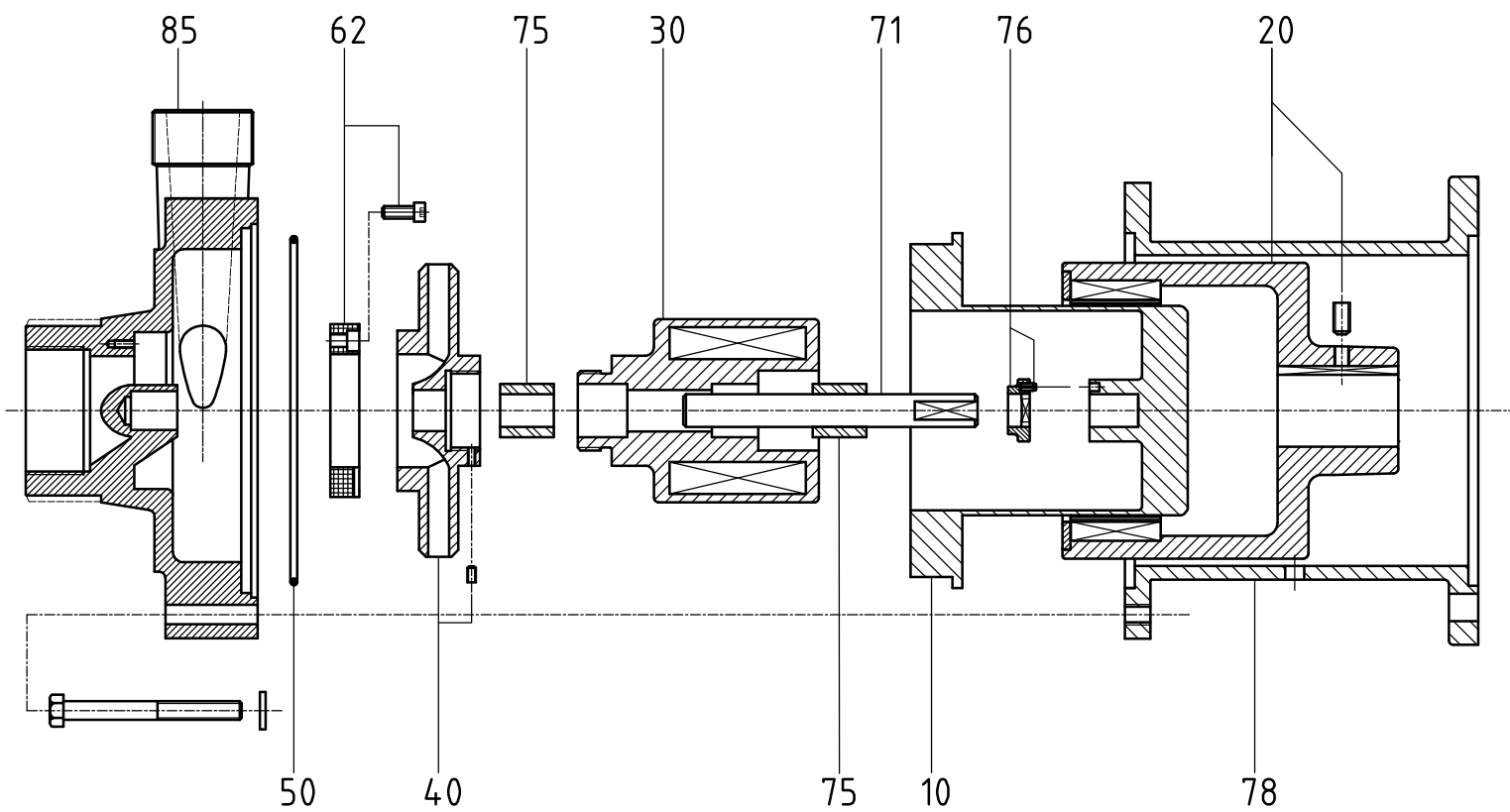

MARCH PUMPEN GmbH & Co.KG
 Rathenastraße 2
 D-35394 Gießen

www.march-pumpen.com
 info@march-pumpen.com

Baureihe / Series:

EUROLINE

Typ / Type:

M6.1 AISI316

Motor:

IEC 71 B35