

MAGNETICALLY COUPLED ROTARY SLIDING VANE PUMP

Series VANE-MAG MPA

MPA 614 - 814 - 1014 (MPA II° Range)

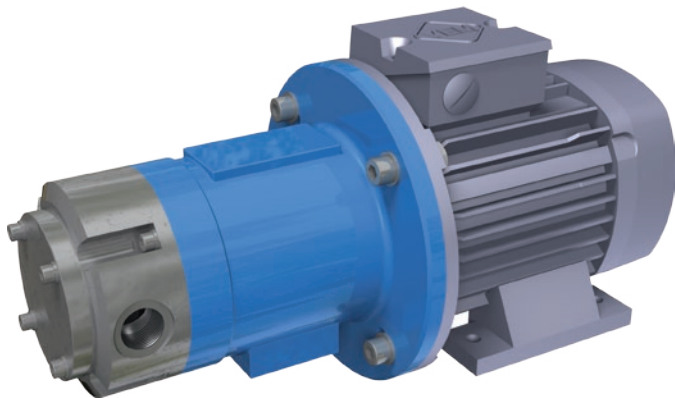

PERFORMANCE DATA

Nominal speed:	1450 1/min / 1750 1/min
Nominal frequency:	50 Hz / 60 Hz
Nominal flow rate:	
MPA 614:	600 l/h / 750 l/h (198,13 US gph)
MPA 814:	800 l/h / 975 l/h (257,57 US gph)
MPA 1014:	950 l/h / 1150 l/h (303,80 US gph)
Discharge pressure, max:	13 bar (188,55 psi)
Design pressure:	PN 16 bar (232,06 psi)
	>PN16 on request
Temperature, max.:	-40°C ... 120°C (-40° ... 248°F)
	>120°C on request
Viscosity, max.:	5000 mPa s
Density, max.:	1,9 kg/dm³

APPLICATIONS

The VANE-MAG® sliding vane pumps have proven their performance in every application that requires lower flow rates at high discharge pressure, when corrosive liquids must be metered.

Typical Applications:

- Ammonia metering in Flue-Gas Denitrification Plants (SNCR)
- Pentane metering in Polyurethane Insulation Production Plants
- Metering pump for Sodium Methylate in Biodiesel production
- Pump for cooling agents in refrigeration technology
- Dosing / metering applications
- Plant Engineering
- Equipment Engineering
- Pharmaceutical-, Medical-, Bio- Engineering

MATERIALS

Housing:	Stainless steel AISI316Ti
O-Rings:	EPDM, Viton, Kalrez, FEP
Rotor:	Stainless steel AISI316Ti
Stator, Vanes::	Phenoli Resin Carbon-Graphite
Bearings:	SiC

CONNECTIONS

Threads:	G3/4" (f), 3/4" NPT (f)
Lap Joint Flanges:	DN20 PN16, 3/4" ANSI

DESIGN FEATURES

- Rotating positive displacement pump
- Sliding Vane Pump
- Metallic housing materials
- Magnetically coupled
- Leak-Free
- Rugged
- Wet self-priming
- Dry running capable
- Compact block design
- Approximately no pulsation
- Middle to high discharge pressure
- Low capacity flow rates
- Metering capable

PRODUCT DESCRIPTION

MARCH Series: VANE-MAG® MPA pumps are rotary positive displacement pumps, magnetically coupled and made of stainless steel AISI316Ti. Characteristic wise, rotary sliding vane pumps generate low volumetric flows with middle to high discharge pressures and approximately no pulsation. The operating principle is based on radial sliding vanes, which are rotating in an eccentric stator.

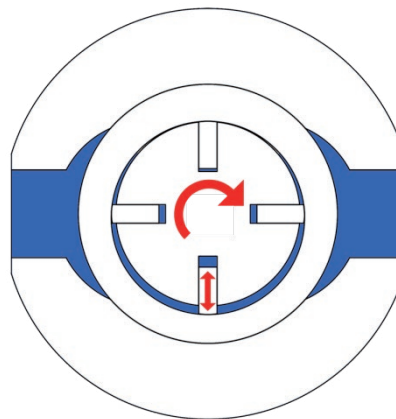

The pump housings are machined of solid block materials.

The motor power is transmitted by a frictional connection to the hydraulic part of the pumps by strong Neodymium-Permanent-Magnets. The pump is able to work without any shaft seals, which guarantees a save and maintenance-free transfer of the liquid without any leakage of corrosive, toxic and explosive fluids. Pumps for hazardous explosive areas, zone 1 or 2, are available upon request.

MOTOR ADAPTION

EU Version:	IEC Size 80 B35, 0,75kW 1500 1/min
US Version:	NEMA143/145TC, 1.0 HP 1750 1/min

H [psi] H [bar]

750 1/min

950 1/min

1450 1/min

1750 1/min

174,0

145,0

116,0

87,0

58,0

29,0

0

100

200

300

400

500

600

700

800

900

1000

1100

Q [l/h]

0,44

0,88

1,32

1,76

2,2

2,64

3,08

3,52

3,96

4,4

4,84

Q [U.S. GPM]



MARCH PUMPEN GmbH
Rathenaustraße 2
D-35394 Gießen

www.march-pumpen.com
info@march-pumpen.com

KENNLINIEN / PERFORMANCE CURVES

Series	VANE-MAG		
Pump Size	MPA 614		
Motor Power	0,18 / 0,25 kW	0,37 / 0,55 kW	0,55 / 0,75 kW
Speed	750 / 900 1/min	900 / 1150 1/min	1450 / 1750 1/min
Fluid Viscosity	1 mm ² /s	Fluid Density	1 kg/dm ³

H [psi] H [bar]

750 1/min

950 1/min

1450 1/min

1750 1/min

174.0
145.0
116.0
87.0
58.0
29.0
0

0 100 200 300 400 500 600 700 800 900 1000 1100 Q [l/h]
0.44 0.88 1.32 1.76 2.2 2.64 3.08 3.52 3.96 4.4 4.84 Q [U.S. GPM]



MARCH PUMPEN GmbH
Rathenaustraße 2
D-35394 Gießen
www.march-pumpen.com
info@march-pumpen.com

KENNLINIEN / PERFORMANCE CURVES			
Series	VANE-MAG		
Pump Size	MPA 814		
Motor Power	0,18 / 0,25 kW	0,37 / 0,55 kW	0,55 / 0,75 kW
Speed	750 / 900 1/min	900 / 1150 1/min	1450 / 1750 1/min
Fluid Viscosity	1 mm ² /s	Fluid Density	1 kg/dm ³

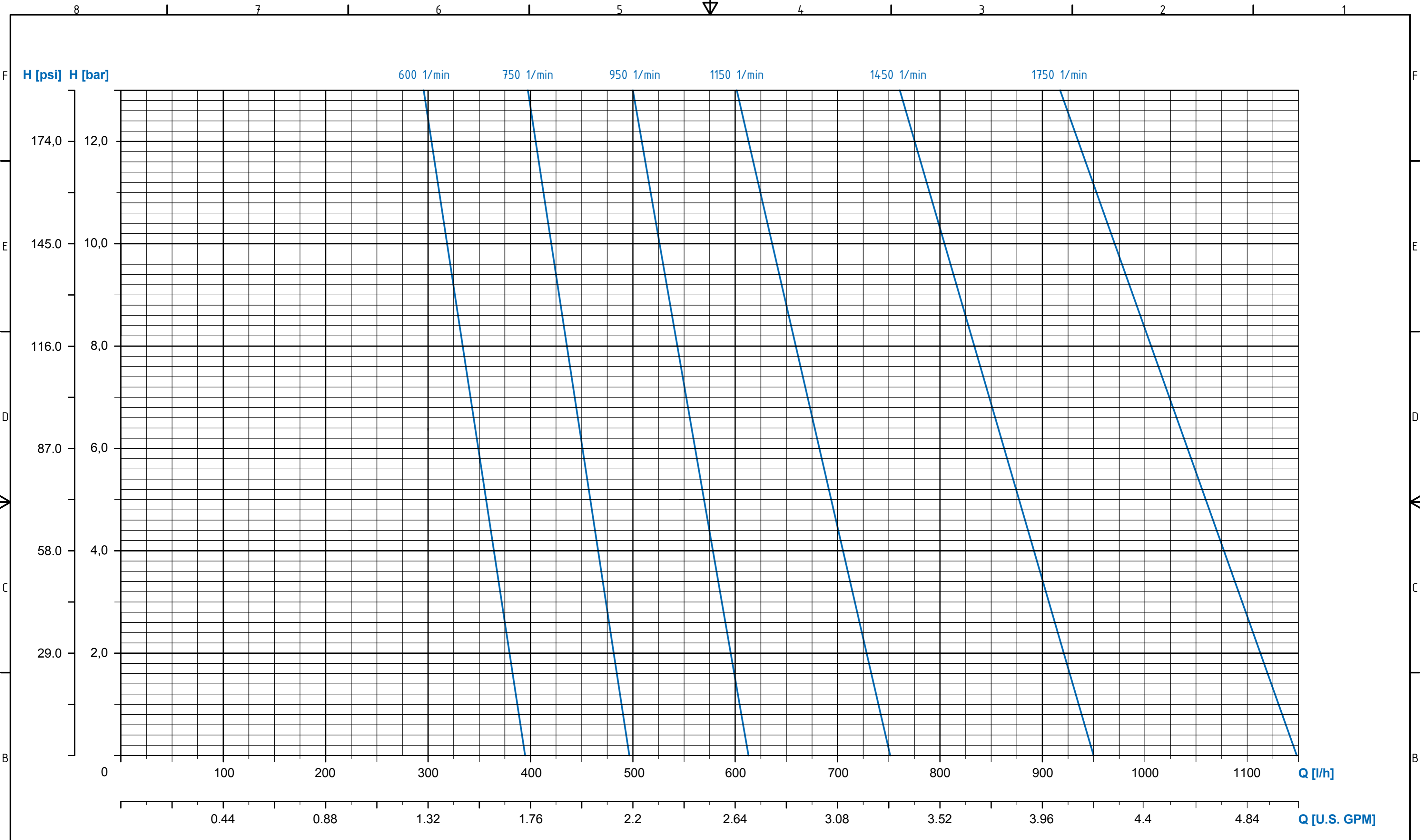

KENNLINIEN / PERFORMANCE CURVES			
Series	VANE-MAG		
Pump Size	MPA1014 - III°Range Pumps		
Motor Power	0,55kW	1,1kW	1,5kW
Speed	750 / 900 1/min	900 / 1150 1/min	1450 / 1750 1/min
Fluid Viscosity	1 mm ² /s	Fluid Density	1 kg/dm ³

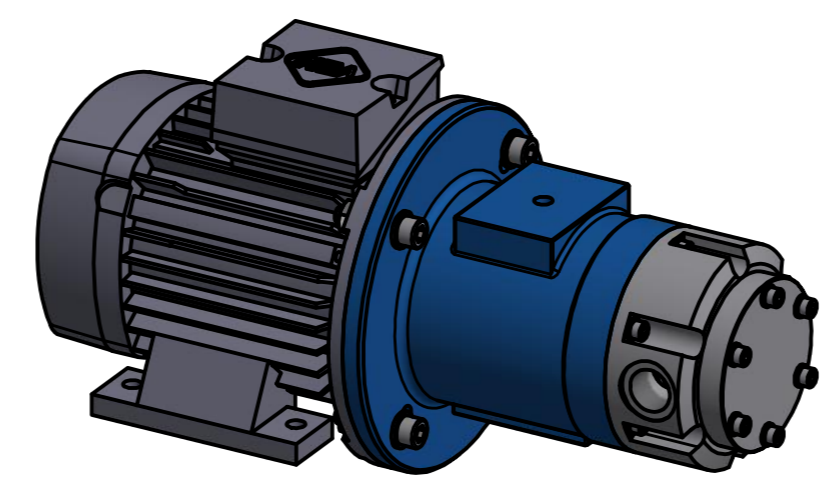
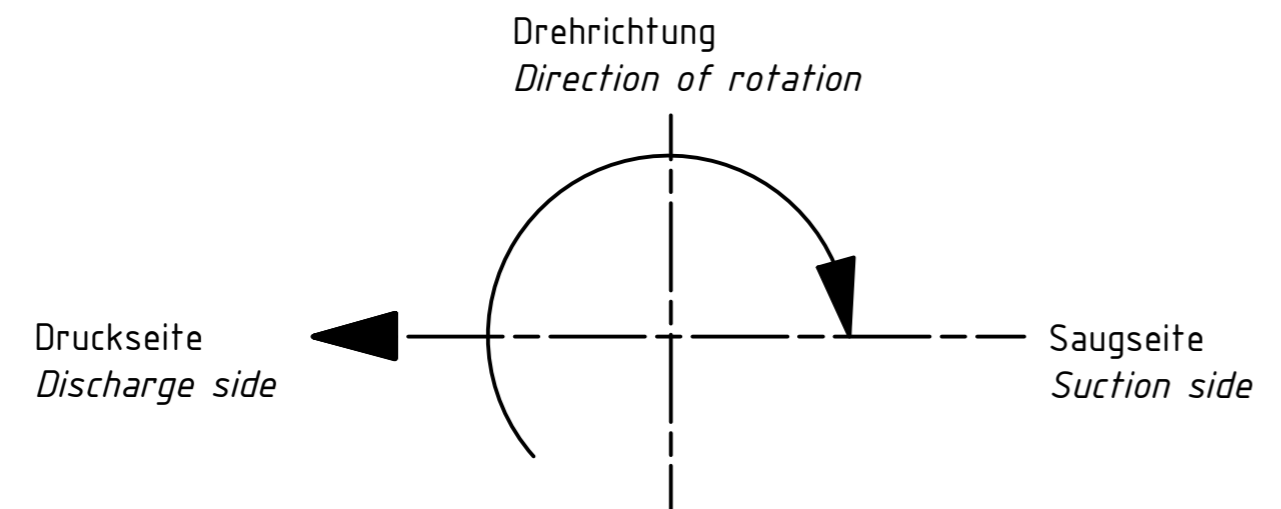
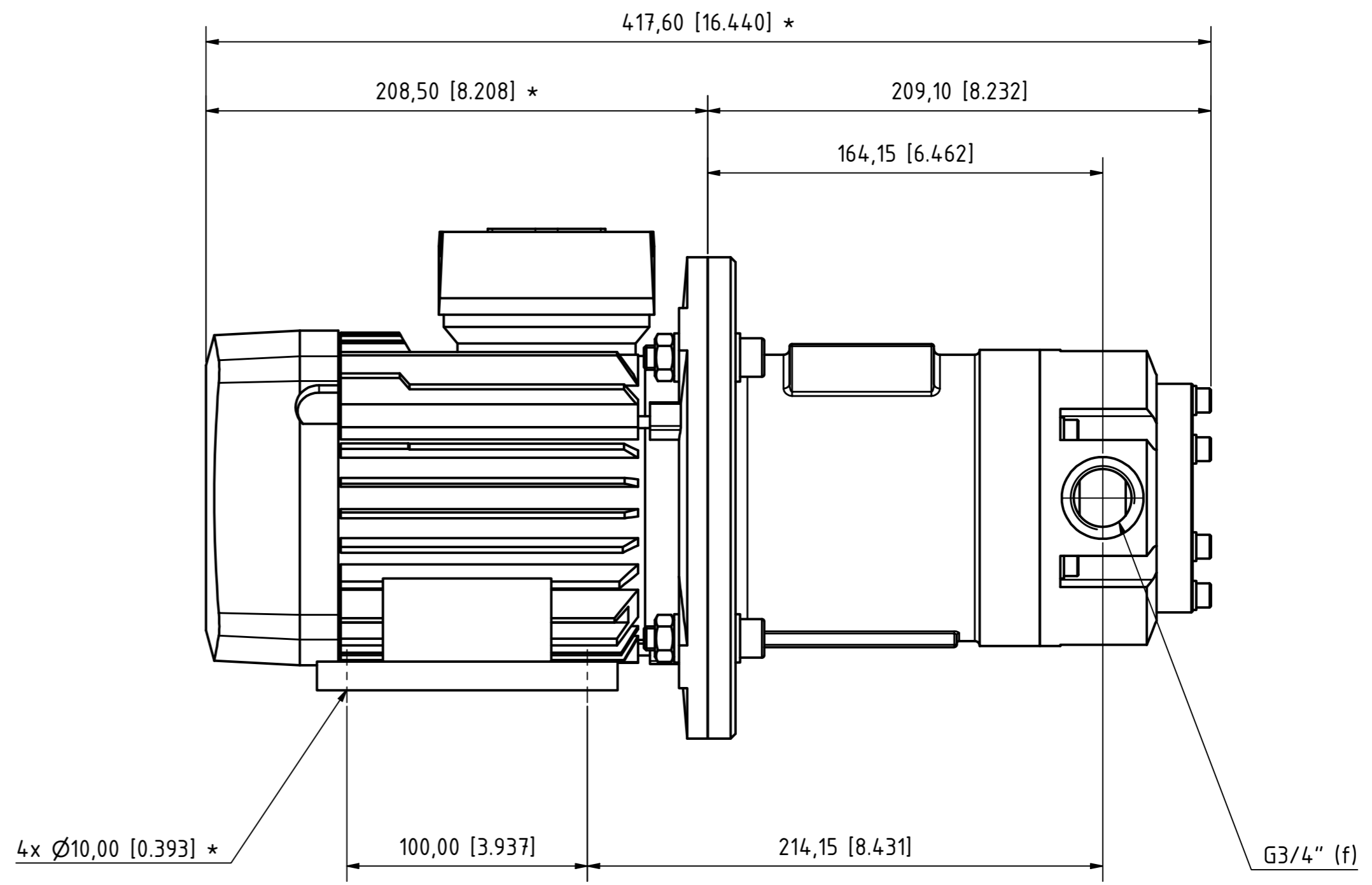
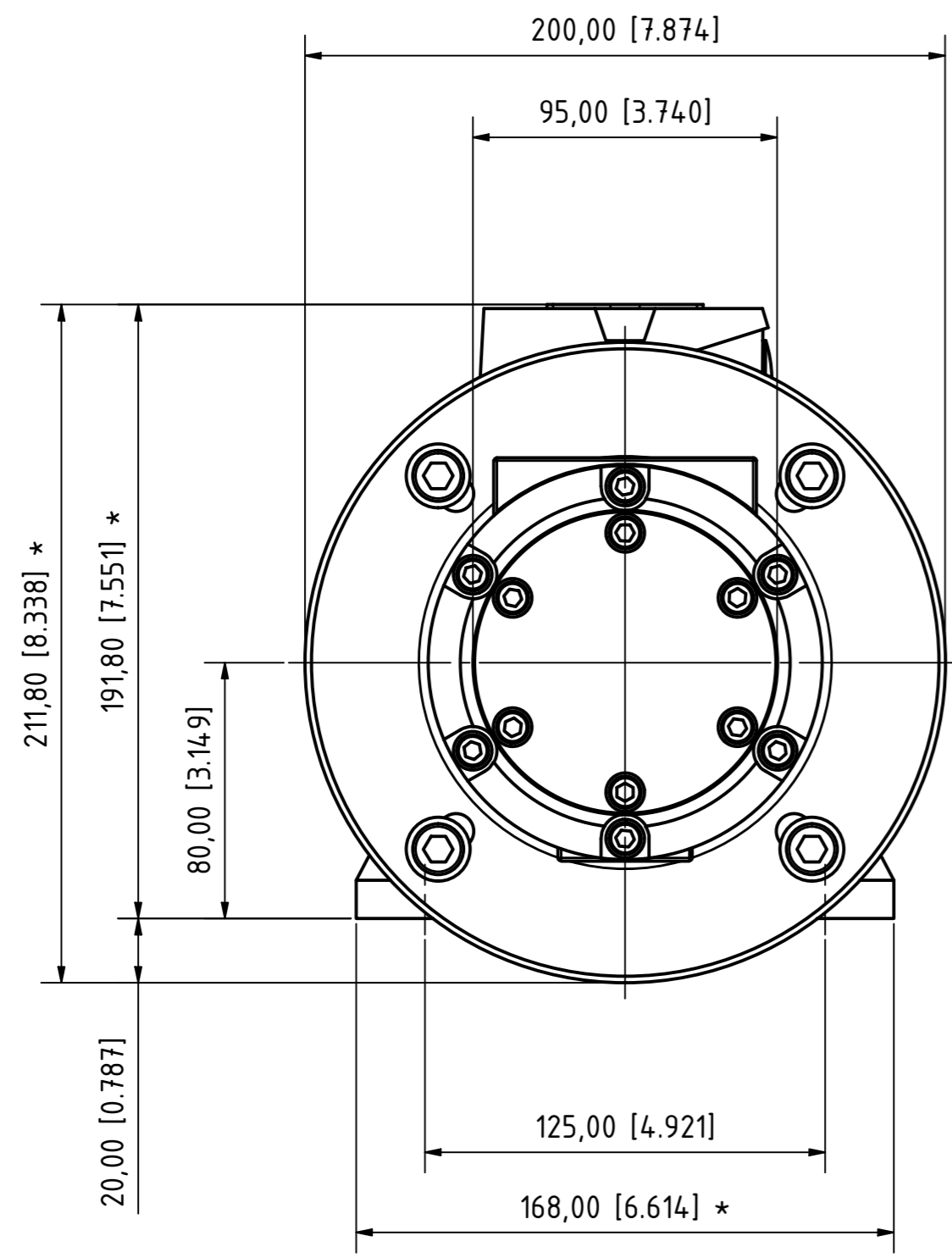

DIMENSIONS
in mm [inch]
* may change with different motor manufacturer

DRIVE
TEFC three phase asynchronous squirrel cage electric motor
acc. to IEC Standards
Manufacturer: VEM
Size: IEC80 B35, 0,75kW, 1450 rpm

CONNECTIONS
3/4" BSP or NPT female
as option:
Lap Joint Flange DN20 PN25 or ANSI 3/4"

Alle Angaben unverbindlich, technische Änderungen vorbehalten! Technical data not binding and subject to change!
Copyright MARCH PUMPEN GmbH & Co.KG 2019

		MARCH PUMPEN GmbH Rätthausstraße 2 D-35394 Gießen Tel.: (+49) (0)641-686806-0 Fax.: (+49) (0)641-686806-60				1:2				
				Datum	Name	VANE-MAG MPA II° Range				
				Gezeichnet	26.07.2019	Lach	SSR - IEC80 - VEM			
				Kontrolliert						
				Norm			MPAII°R_SSR_IEC80_VEM_1			
							A2			
Status	Änderungen	Datum	Name							

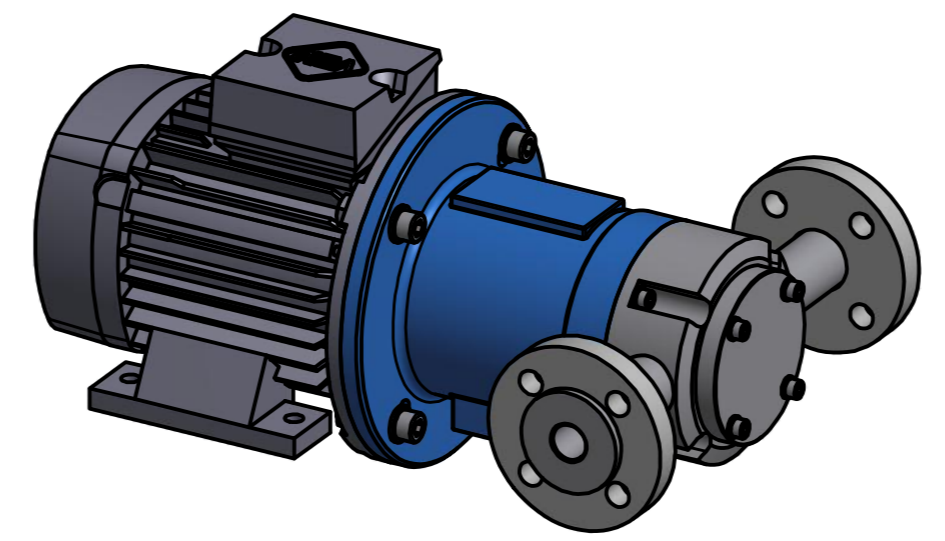
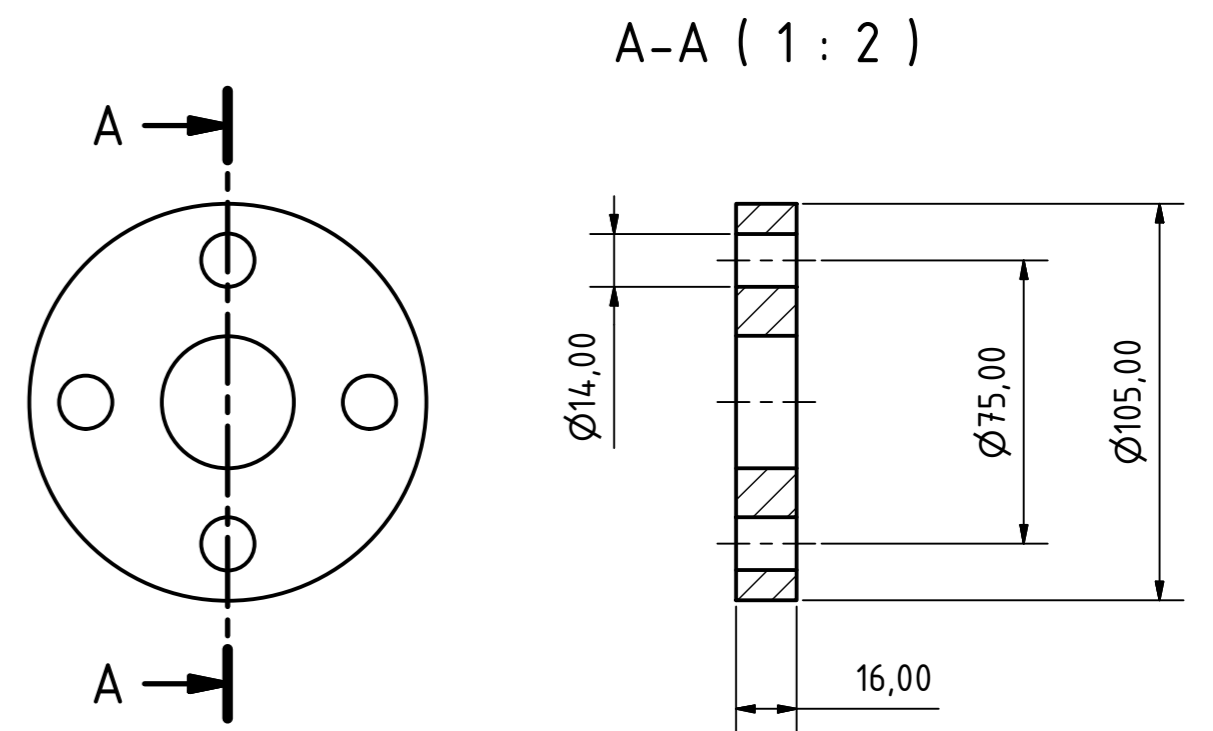
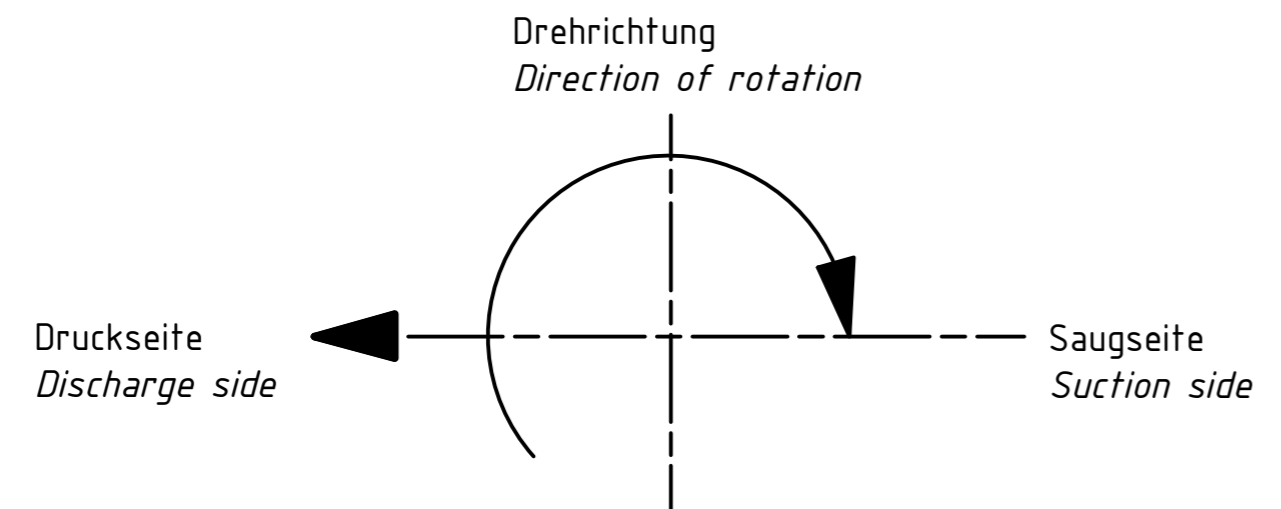
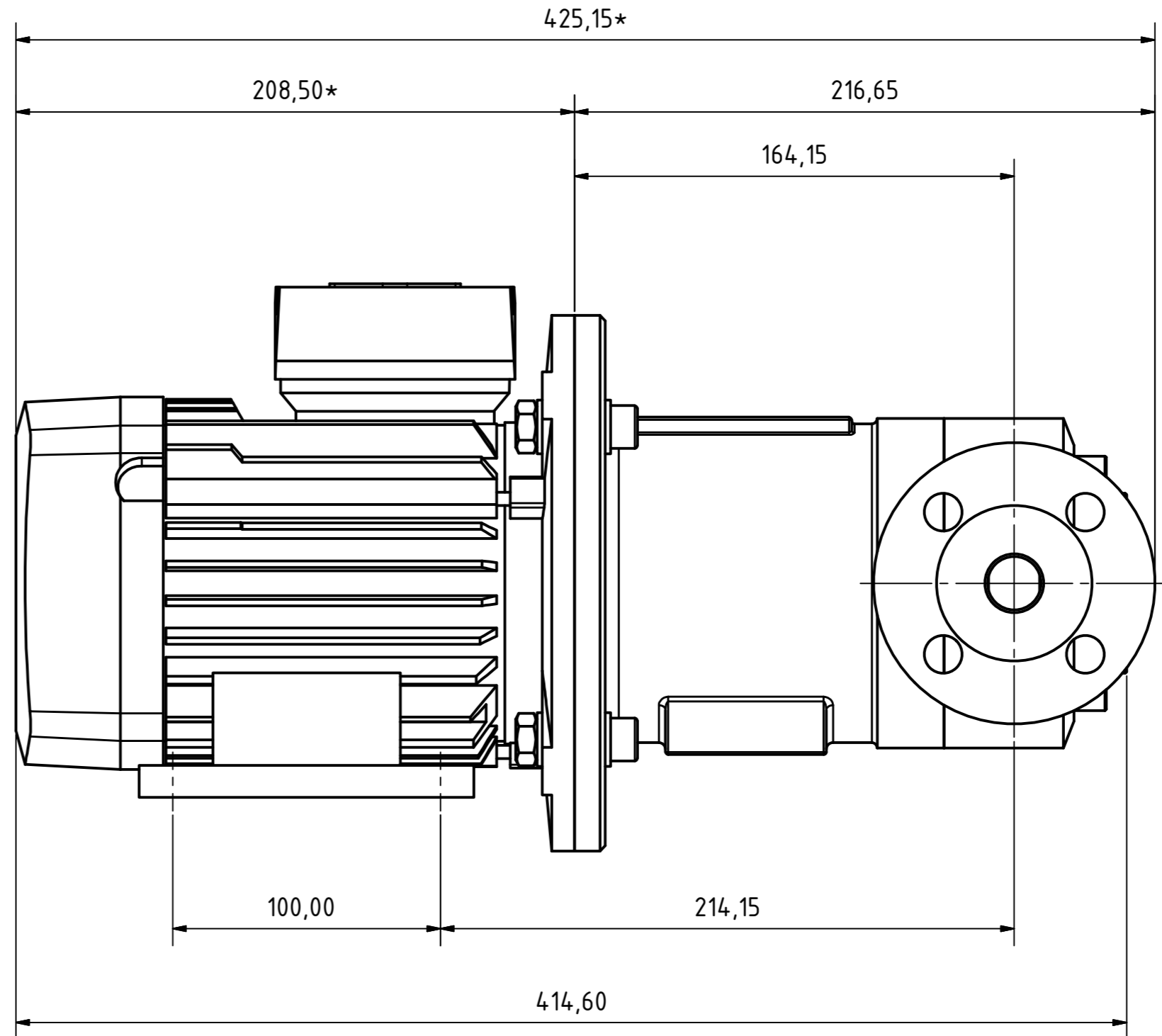
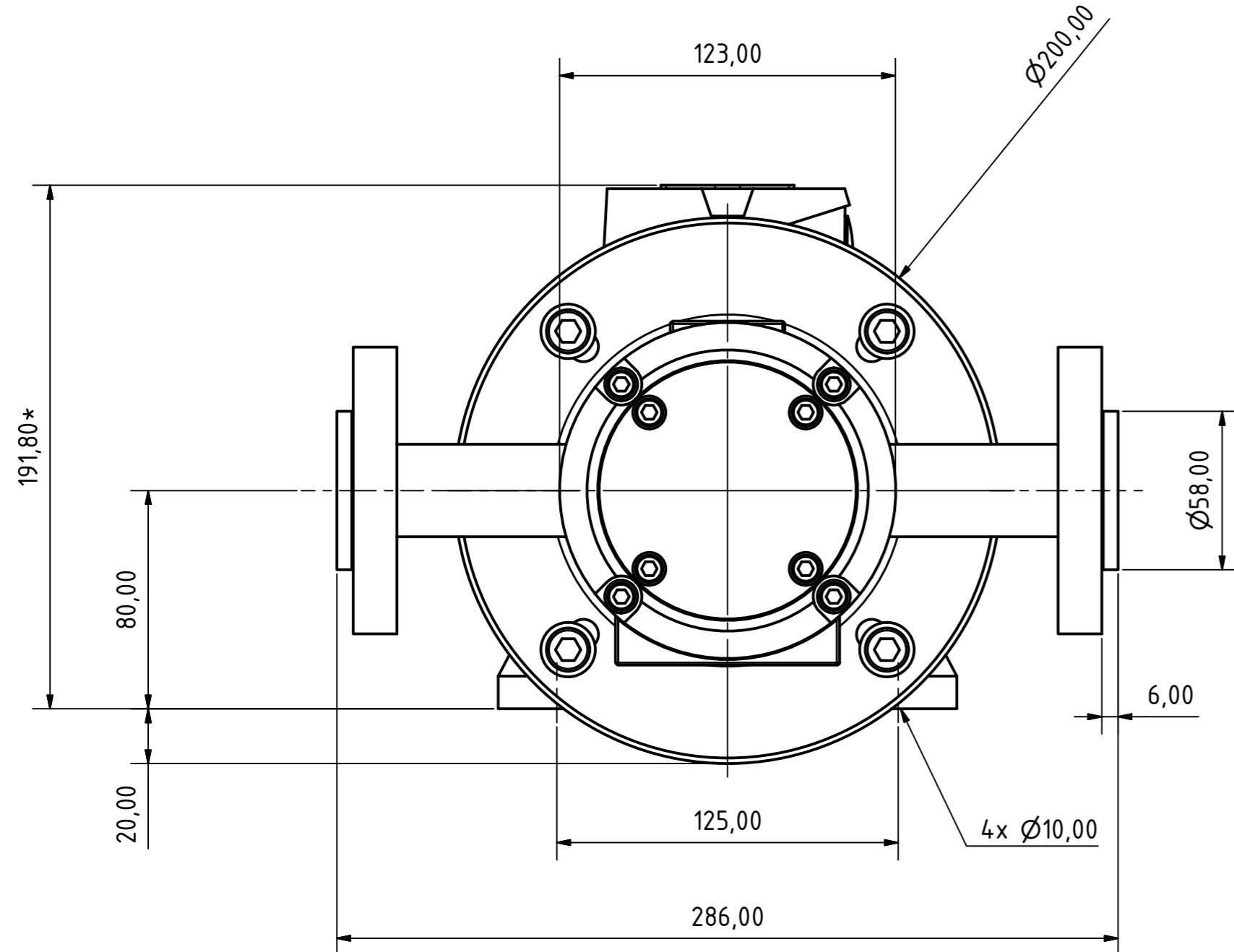

DIMENSIONS
in mm
* may change with different motor manufacturer

DRIVE
TEFC three phase asynchronous squirrel cage electric motor
acc. to IEC Standards
Manufacturer: VEM
Size: IEC80 B35, 0,75kW, 1450 rpm

CONNECTIONS
Lap Joint Flange DN20 PN16
or
3/4" BSP female

Alle Angaben unverbindlich, technische Änderungen vorbehalten! Technical data not binding and subject to change!
Copyright MARCH PUMPEN GmbH & Co.KG 2014

		MARCH PUMPEN GmbH Rälthausstraße 2 D-35394 Gießen Tel.: (+49) (0)641-686806-0 Fax.: (+49) (0)641-686806-60				1:2			
		Gezeichnet: 14.11.2018 Lach		Datum: 14.11.2018 Name: Lach		VANE-MAG MPA II° Range SSF - IEC80 - VEM			
		Kontrolliert: Norm:				DPMPA_II°R_SSF			
								1 A2	
Status	Änderungen	Datum	Name						

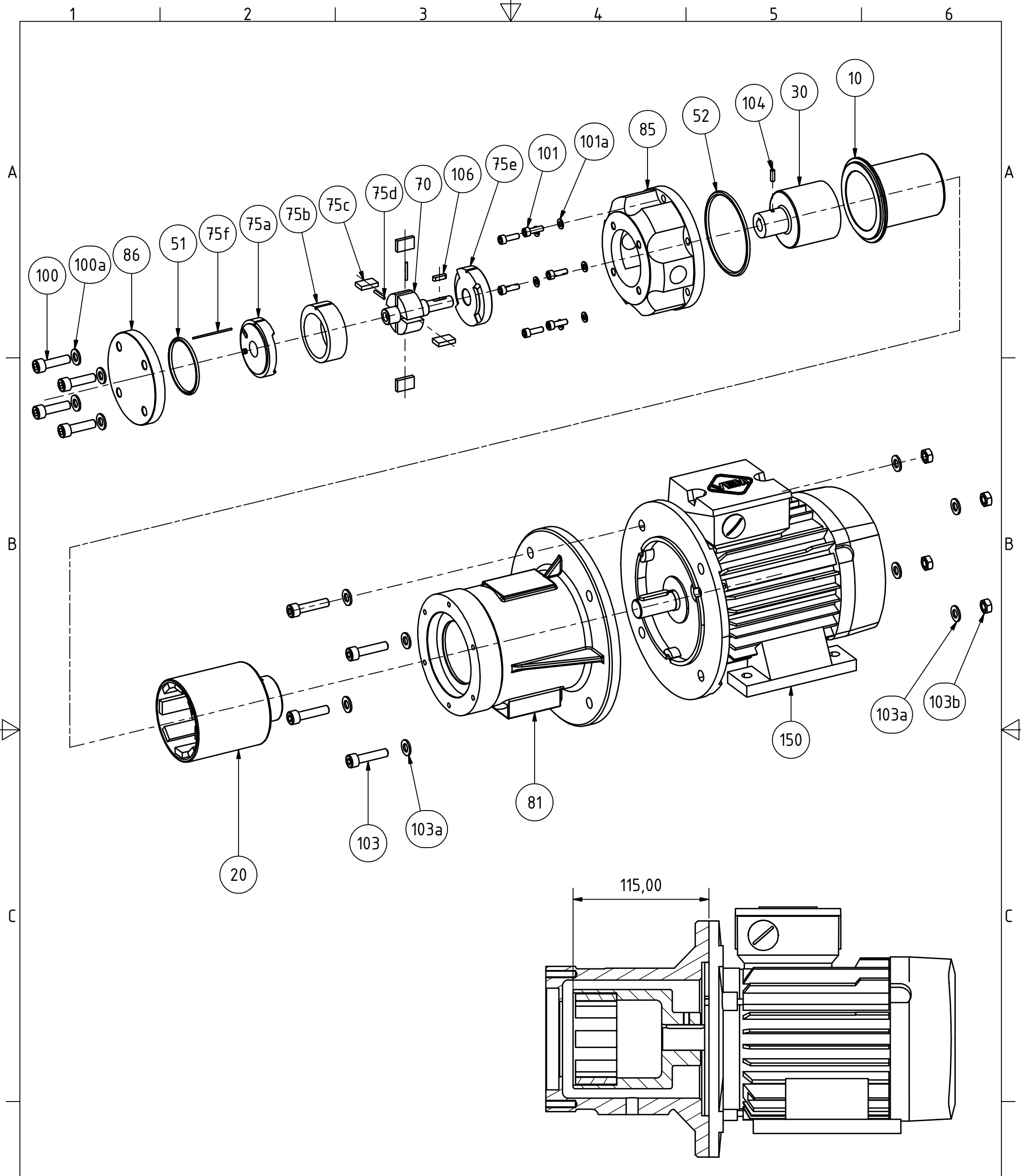

Alle Angaben unverbindlich, technische Änderungen vorbehalten! Technical data not binding and subject to change!
 Copyright MARCH PUMPEN GmbH 2014

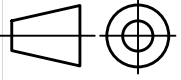
		MARCH PUMPEN GmbH & Co.KG Rathenastraße 2 D-35394 Gießen info@march-pumpen.com www.march-pumpen.com					
		Datum		Name		Explosionsdarstellung	
		Gezeichnet: 02.09.2015		P.Stachon		Explosion View	
		Kontrolliert:				Baureihe / Series MPA II	
		Norm:					
						EXPL_MPA_II	
						1	
						A3	
Status	Änderungen	Datum	Name				