

# MAGNETIC DRIVEN REGENERATIVE TURBINE PUMPS

Series MTA

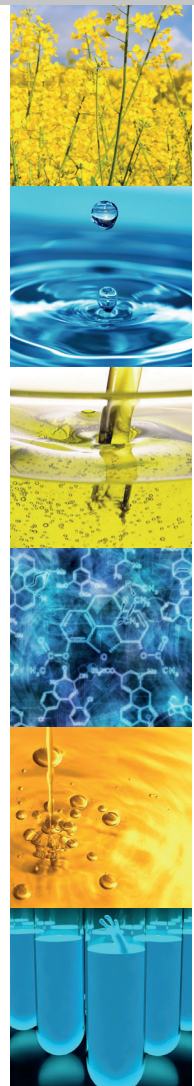
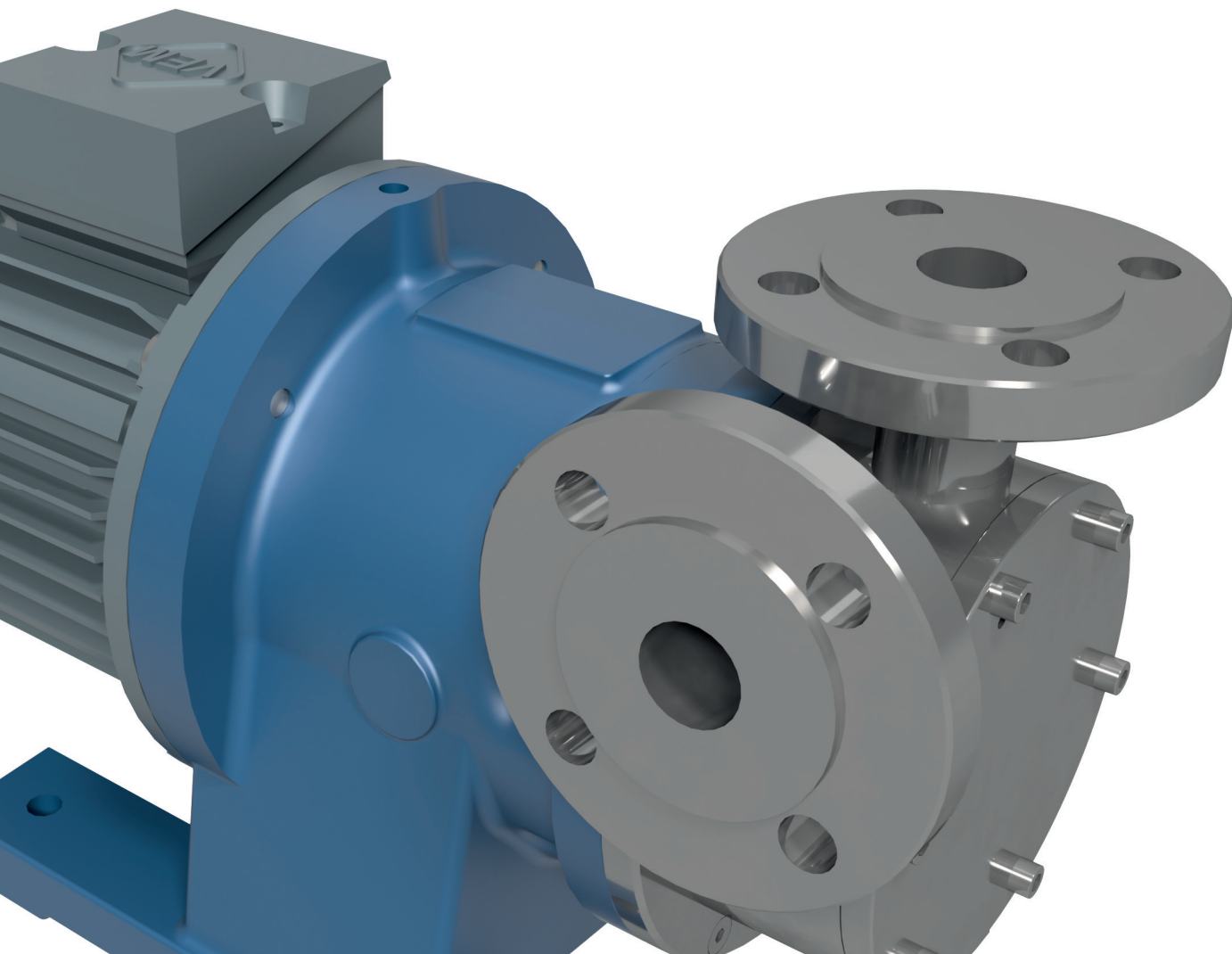

...ADVANCED  
SOLUTIONS...

# MAGNETIC DRIVEN REGENERATIVE TURBINE PUMP

## Series MTA

MTA 25, 37, 49, 78, 1011, 2020

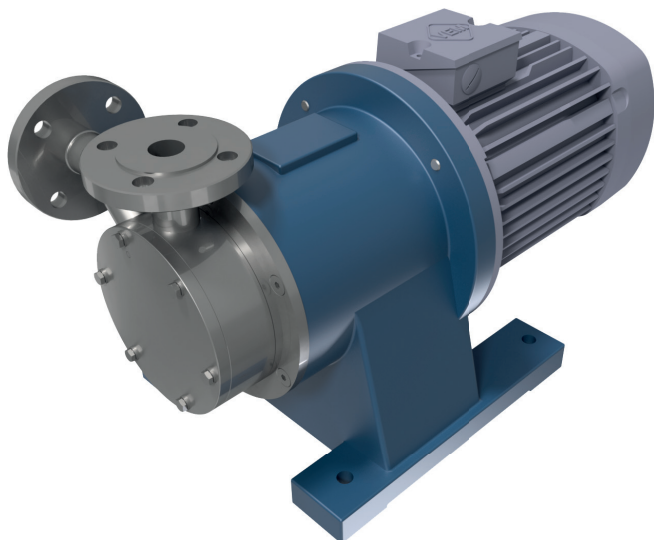

### TECHNICAL DATA

Nominal Speed:	2900 1/min
Capacity flow, max. / head, max.:	
MTA 25:	1,8 m <sup>3</sup> /h / 35m
MTA 37:	3,5 m <sup>3</sup> /h / 45m
MTA 49:	4,7 m <sup>3</sup> /h / 62m
MTA 78:	7,0 m <sup>3</sup> /h / 73m
MTA 1011:	9,8 m <sup>3</sup> /h / 90m
MTA 2020:	17,0 m <sup>3</sup> /h / 174m
Design Pressure:	16 ... 250 bar
Temperature:	-150 °C ... 315 °C
S.G., max.:	1,8 kg/dm <sup>3</sup>
Viscosity, max.:	200 cP

### PROCESS NOZZLES

MTA 25:	G1/2" (f) / DN15
MTA 37:	G3/4" (f) / DN20
MTA 49:	G1" (f) / DN25
MTA 78:	G1" (f) / DN25
MTA 1011:	G1" (f) / DN25
MTA 2020:	G1 1/2" (f) / DN40

### MATERIALS

Housings: AISI316L, HC276, Duplex, Titan  
O-Rings: EPDM, FKM, FFKM, FEP  
Bearings: PTFEC/G, Graphite, SiC  
Shaft: SiC, AISI316L

\*custom materials or executions available upon request

### APPLICATIONS

Main applications for this particular type of pumps are:

- Booster pump or CIP pump in chemical, food- or pharmaceutical industry.
- Circulation pump for cooling liquids with high temperature delta.
- Filterpump in the electroplating industry or reversible osmosis.

### FEATURES / BENEFIT

- Different sizes available:
- MTA25, 37, 49, 78, 1011, 2020
- High head, low flow
- Leak-free
- Maintenance-free
- Can handle up to 20% entrained gas
- Reversible
- Heavy duty design for industrial applications
- Casing is made from solid block material
- Compact close coupled design
- Liquid gases, solvents. Toxic fluids and explosive fluids.

### PRODUCT DESCRIPTION

MARCH Magnetically Coupled Regenerative Turbine Pumps are suitable for leak-free transport of aggressive or toxic liquids and fluids which are harmful to the environment. Especially designed for media which need to be pumped with a low flow rate and a high discharge head. The magnetic coupling guarantees an absolutely impermeable hermetic cabin of the pump. At the same time the construction of the pump allows a transport of gas content in the pumped liquid up to 20 Vol % without any problem. For applications in food- and pharmaceutical industries, pumps with electrolytic polished surfaces are available.

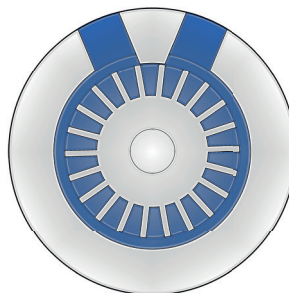

A large number of turbine vanes produce comparably high pressure by transport of small quantities. The friction bearings of the pump are finished with side channels so that the gas in the fluid can be transported without causing dry running. The transmission of energy in the driving gear in the hydraulic part is a result of permanent magnets which make the pumps leak-free and maintenance-free. The pumps will be manufactured in the appropriate compact close coupled block design, for applications with high or low temperatures the pump is available as long coupled process design pump with base frame skid. The pump is also available in the newest ATEX execution

MTA 2900 RPM (50 Hz)

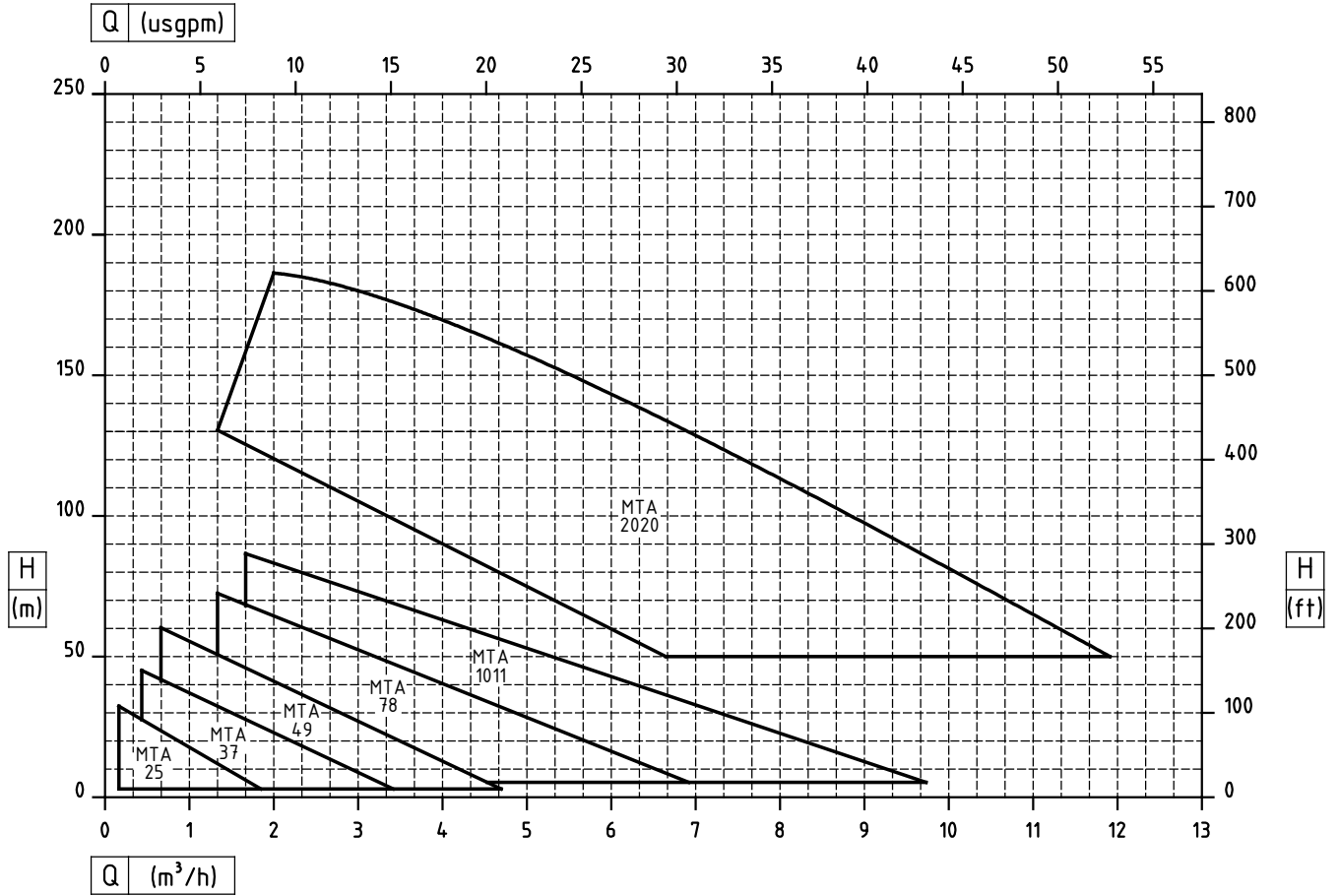

MTA 1450 RPM (50 Hz)

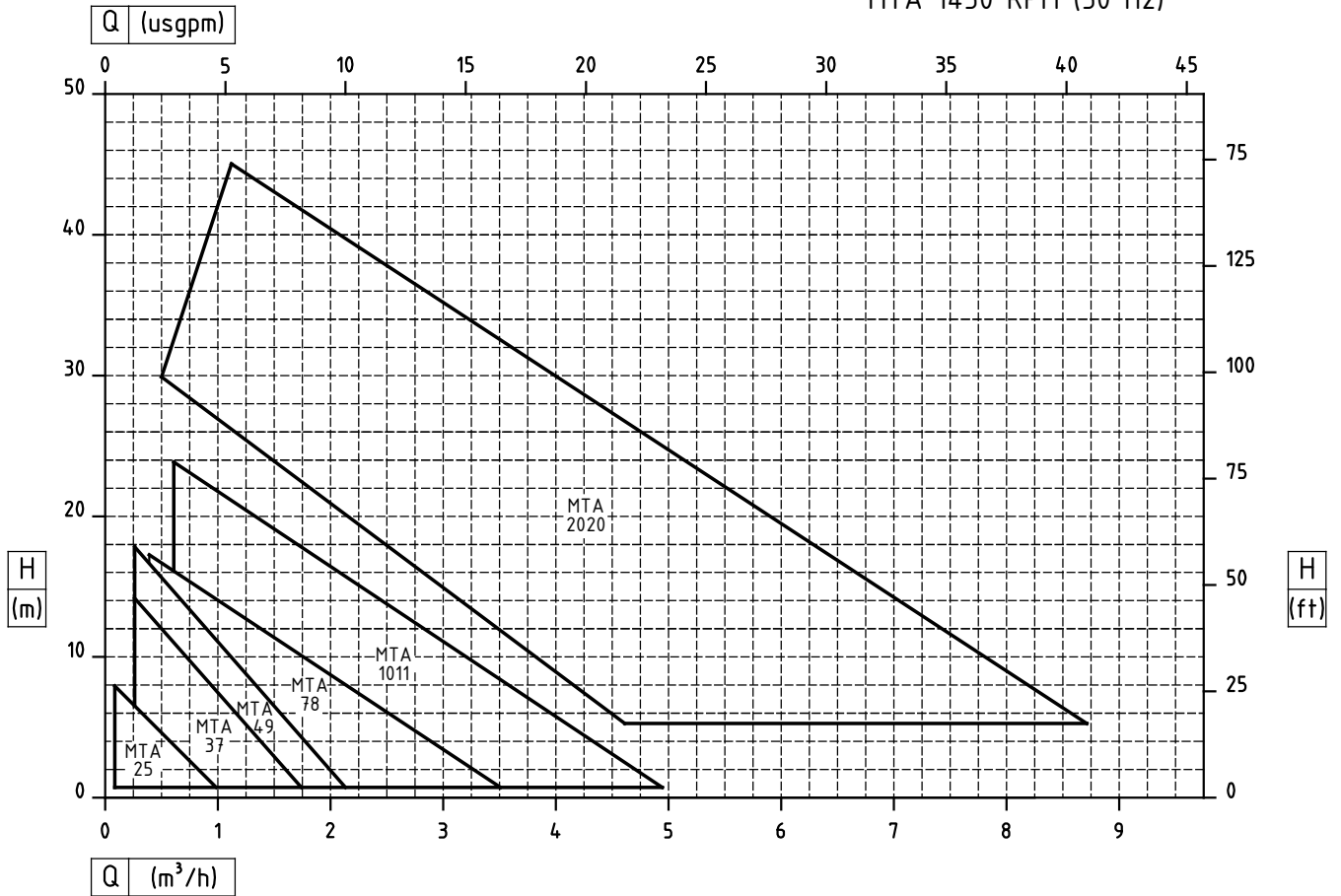

**MARCH PUMPEN GmbH & Co.KG**  
 Rathenastraße 2  
 D-35394 Gießen  
 www.march-pumpen.com  
 info@march-pumpen.com

Baureihe / Series:	MTA
Typ / Type:	Family Curves
Motor Speed:	2900 / 1450 RPM (50 hz)

### FAMILY CURVES MTA 3500 RPM (60Hz)

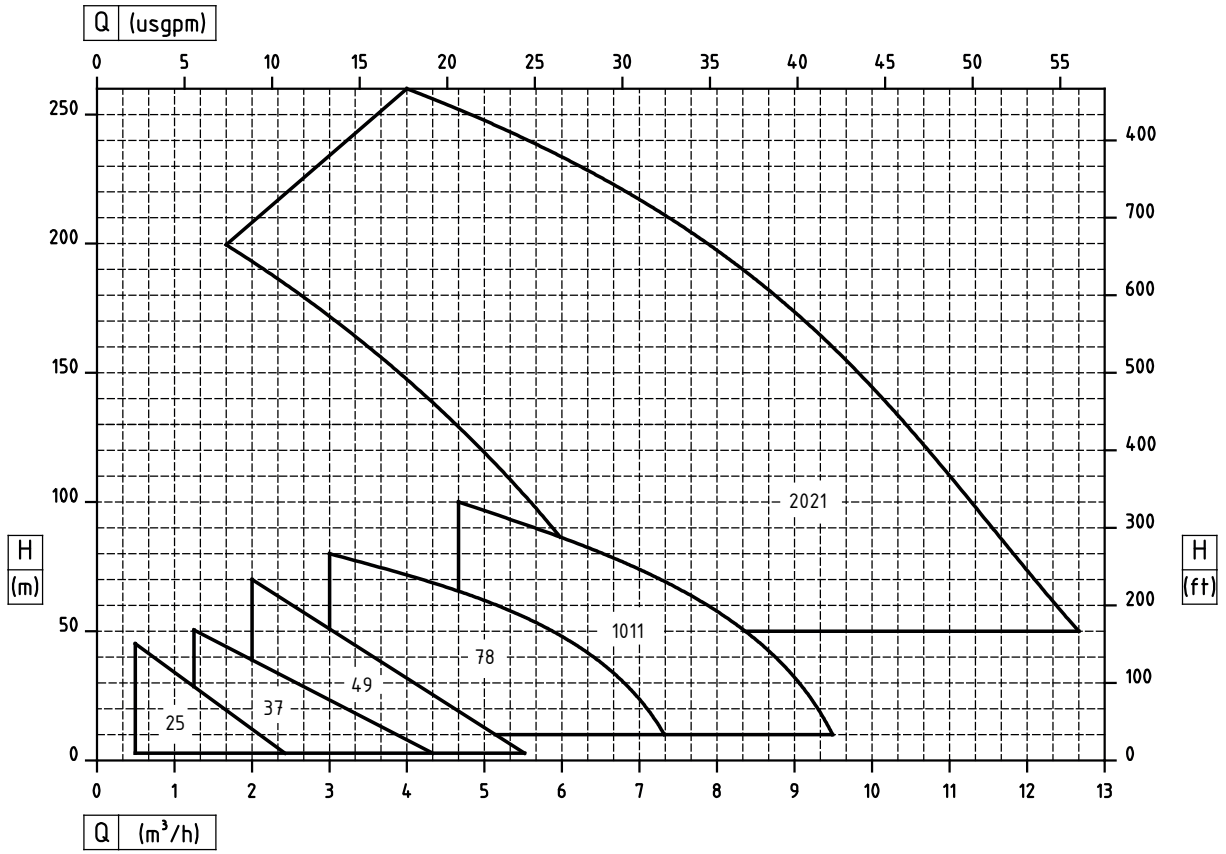

### FAMILY CURVES MTA 1750 RPM (60Hz)

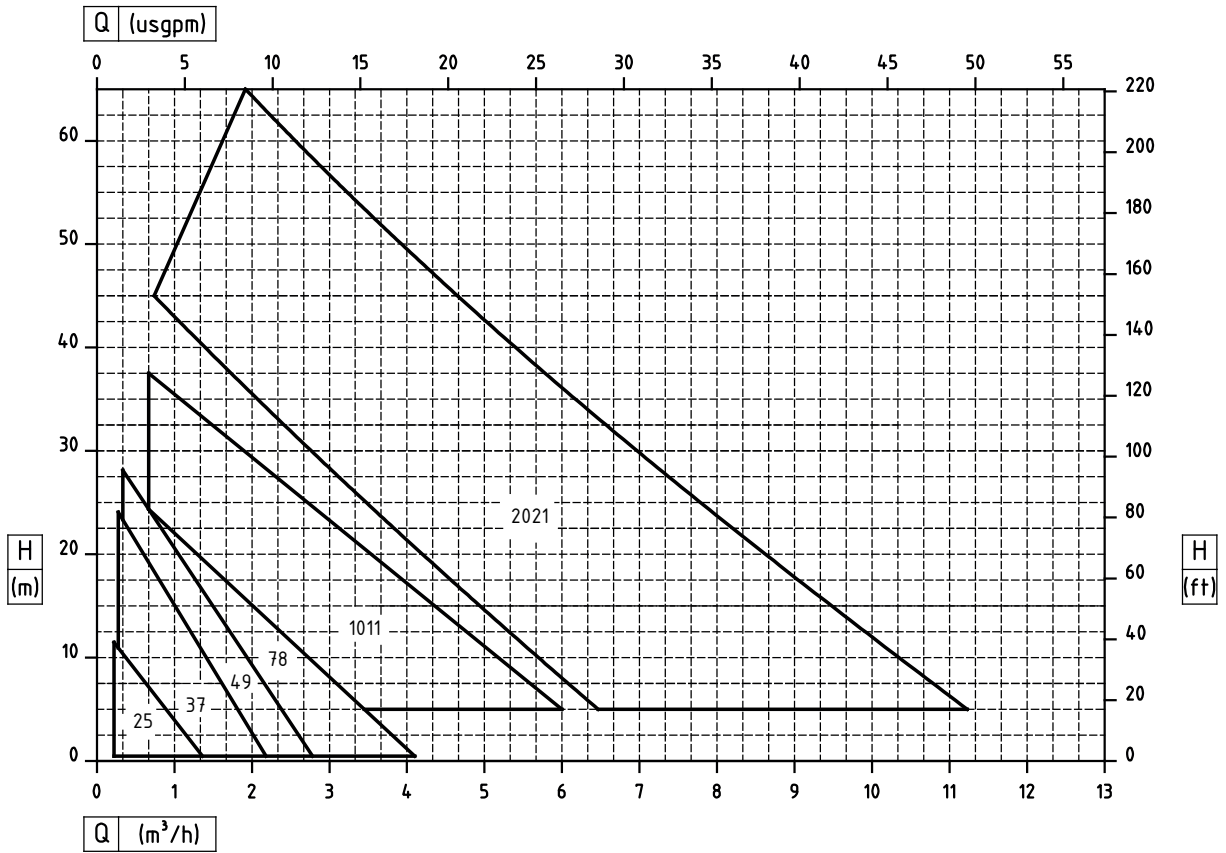

**MARCH PUMPEN GmbH & Co.KG**  
 Rathenaustraße 2  
 D-35394 Gießen  
 www.march-pumpen.com  
 info@march-pumpen.com

Baureihe / Series:	MTA
Typ / Type:	Family Curves
Motor Speed:	3500 / 1750 RPM (60 hz)



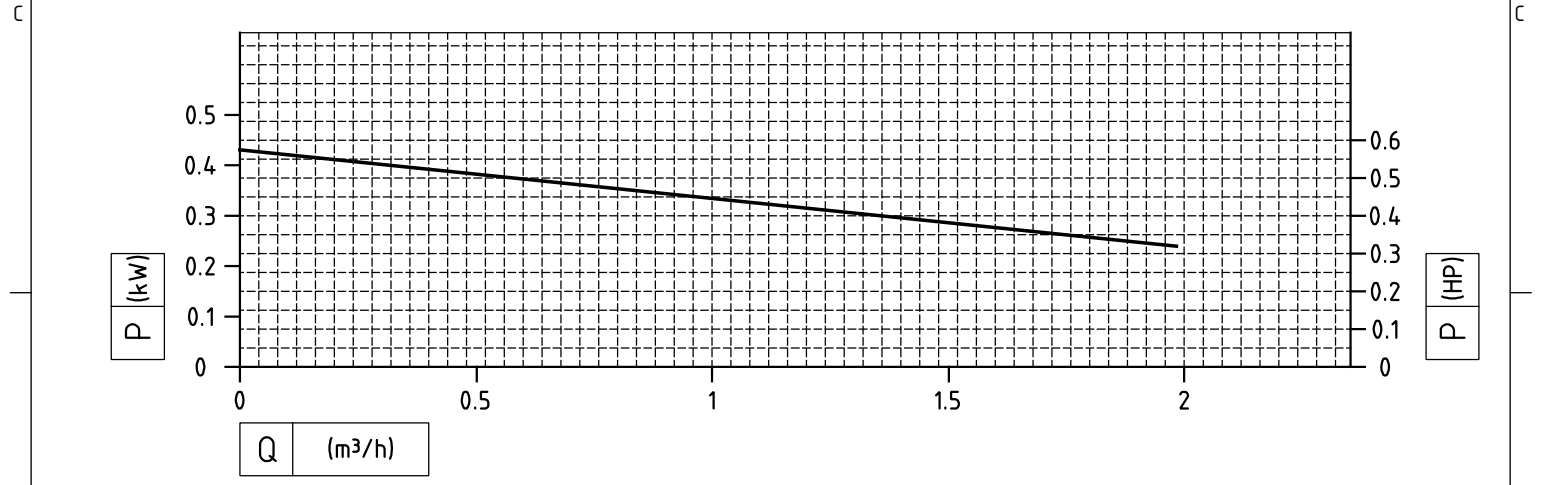
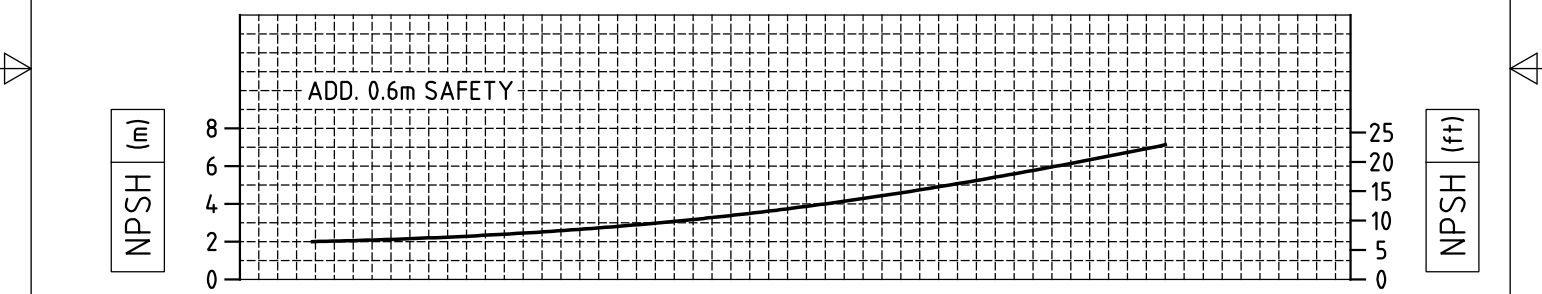
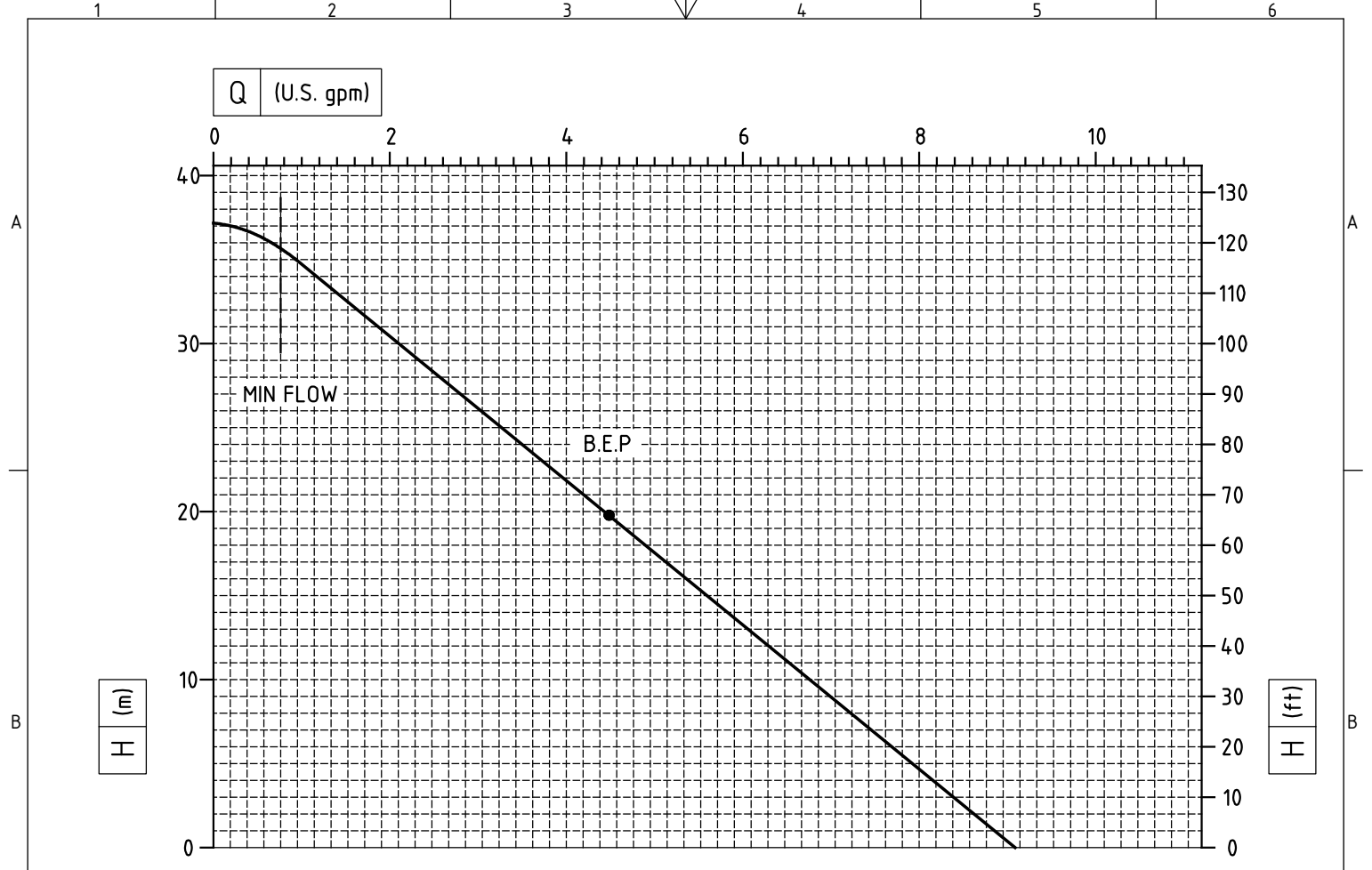

Motor power depends on specific gravity of pumped liquid.

 <p><b>MARCH PUMPEN GmbH &amp; Co.KG</b>  Rathenaustraße 2  D-35394 Gießen  www.march-pumpen.com  info@march-pumpen.com</p>	Baureihe / Series:	MTA
	Typ / Type:	MTA 25
	Motor:	2900 1/min

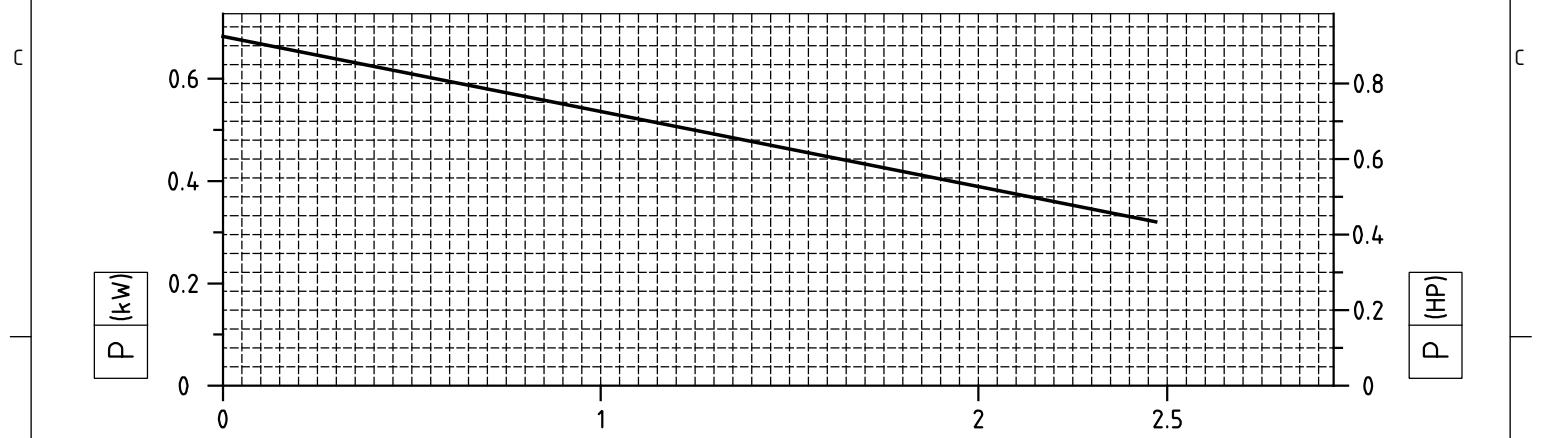
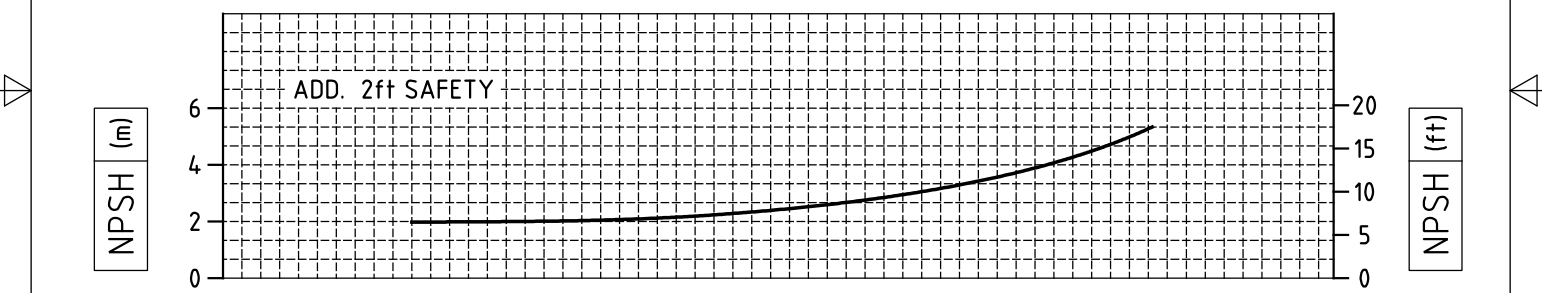
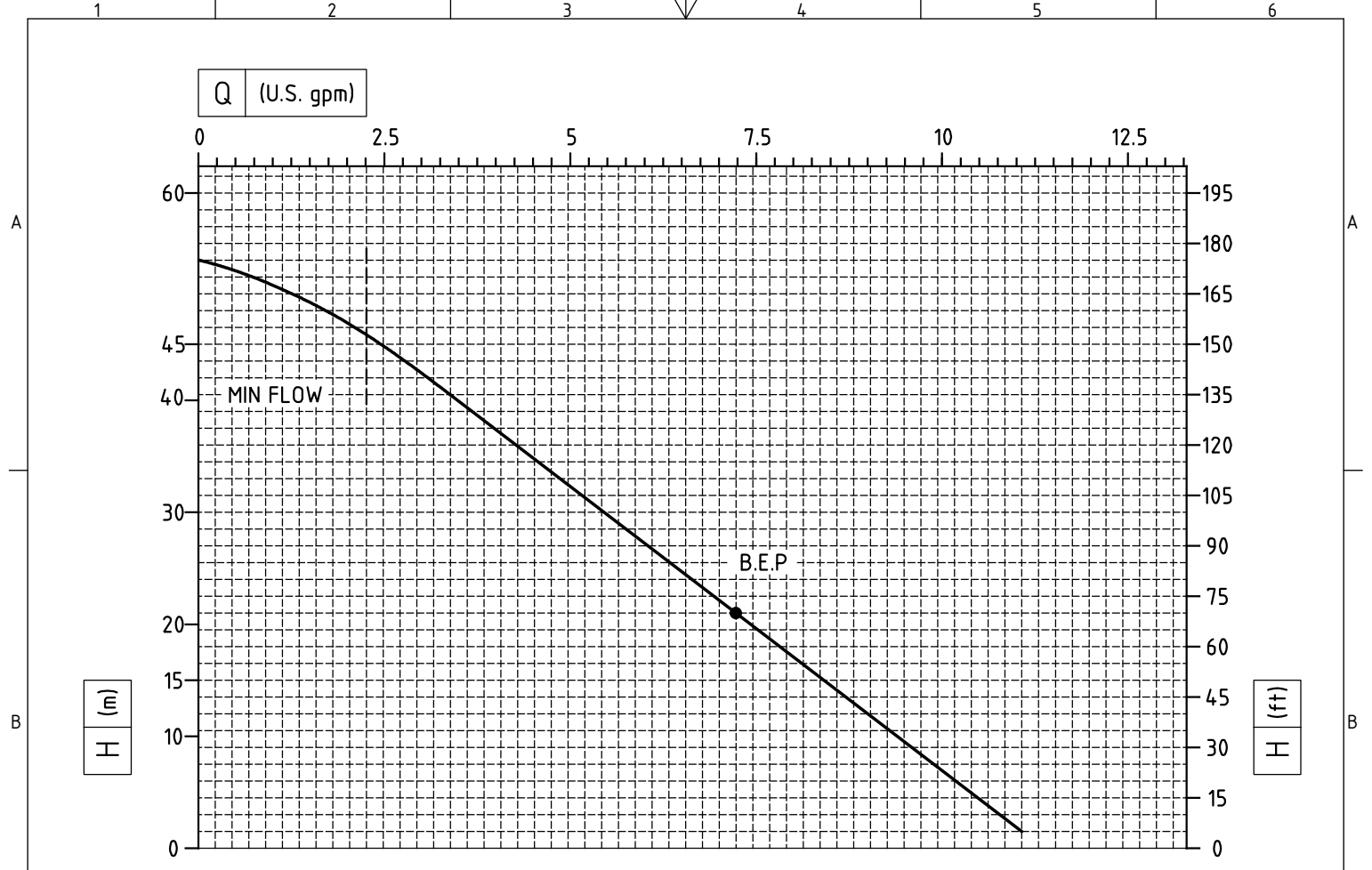

- Motor power depends on specific gravity of pumped liquid.

 <p><b>MARCH PUMPEN GmbH &amp; Co.KG</b>          Rathenastraße 2          D-35394 Gießen  <a href="http://www.march-pumpen.com">www.march-pumpen.com</a>  <a href="mailto:info@march-pumpen.com">info@march-pumpen.com</a></p>	Baureihe / Series:	MTA
	Typ / Type:	MTA 25
	Motor Speed:	3500 1/min

Q (U.S. gpm)

0 1 2 3 4 5 6 7 8 9 10 11 12 13

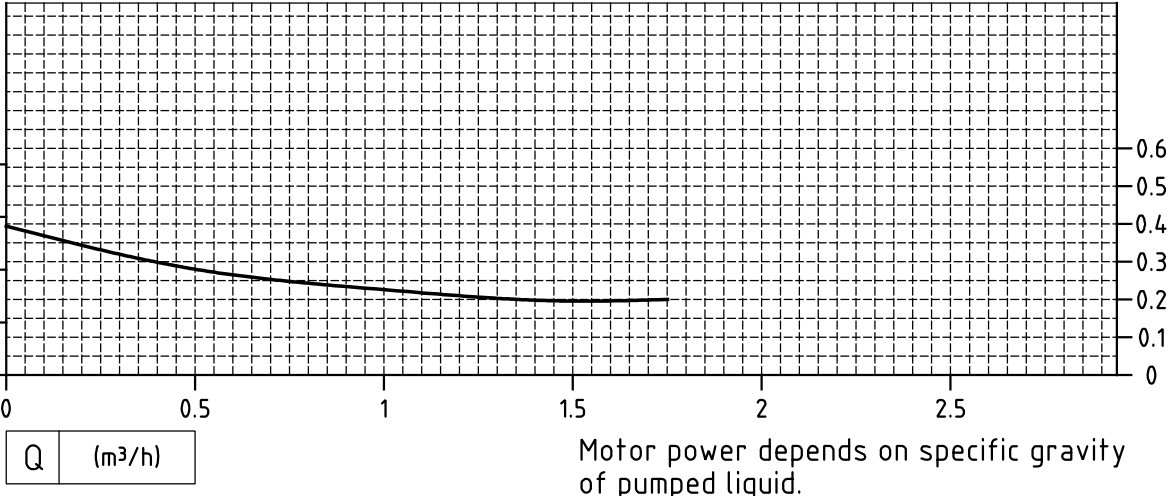
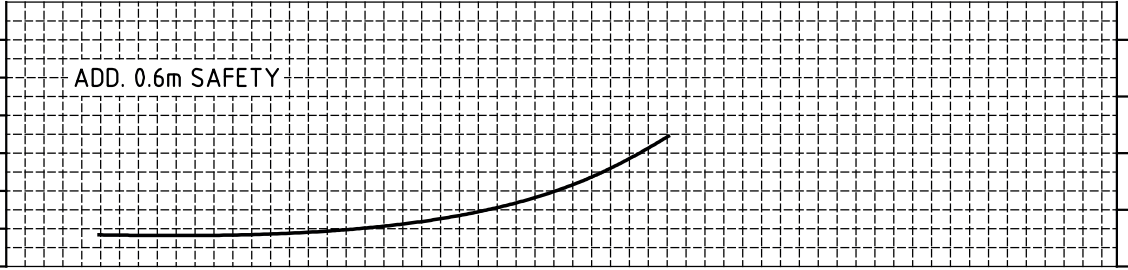
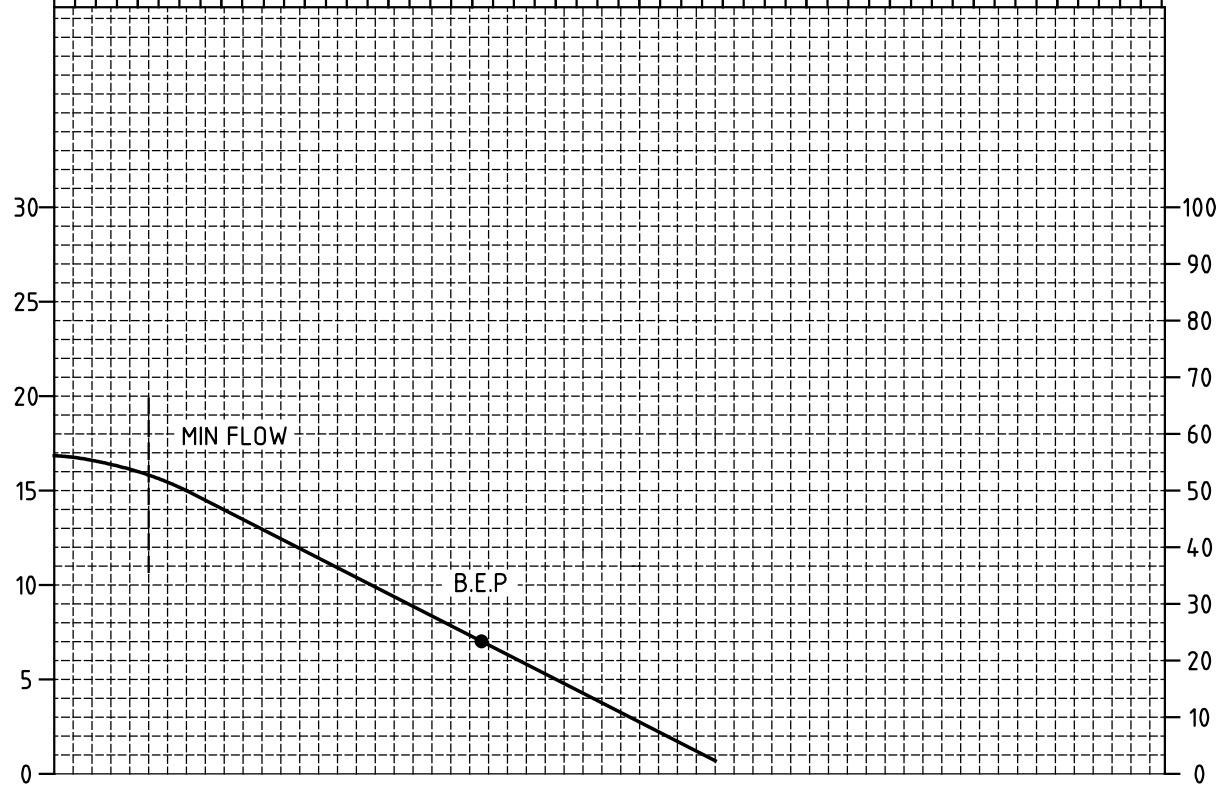

Motor power depends on specific gravity of pumped liquid.



**MARCH PUMPEN GmbH & Co.KG**  
 Rathenastraße 2  
 D-35394 Gießen  
 www.march-pumpen.com  
 info@march-pumpen.com

Baureihe / Series:	MTA
Typ / Type:	MTA 37
Motor Speed:	1450 1/min

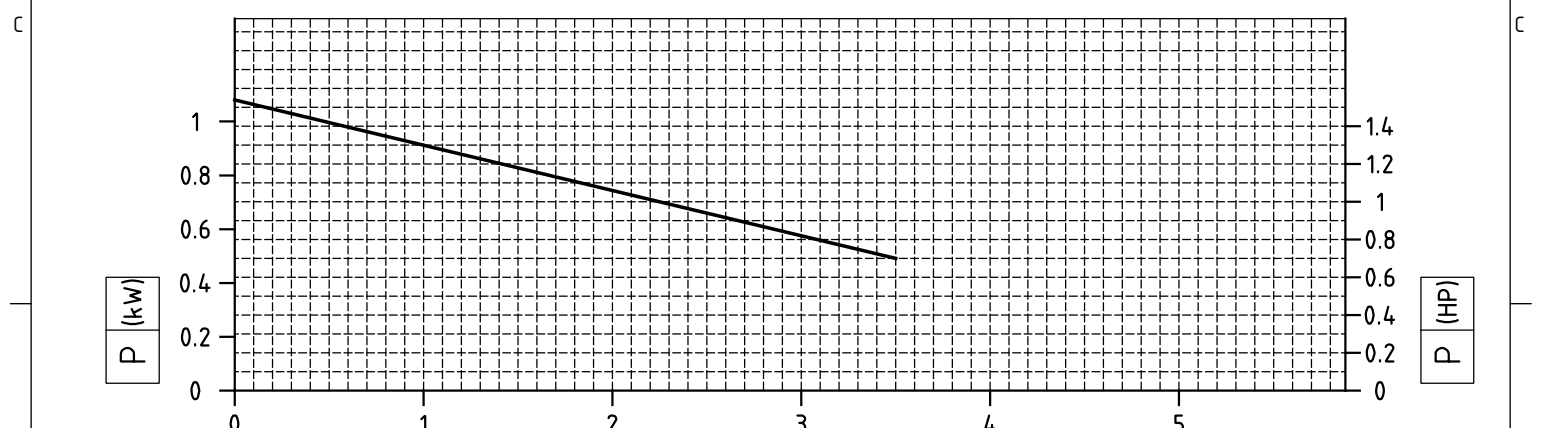
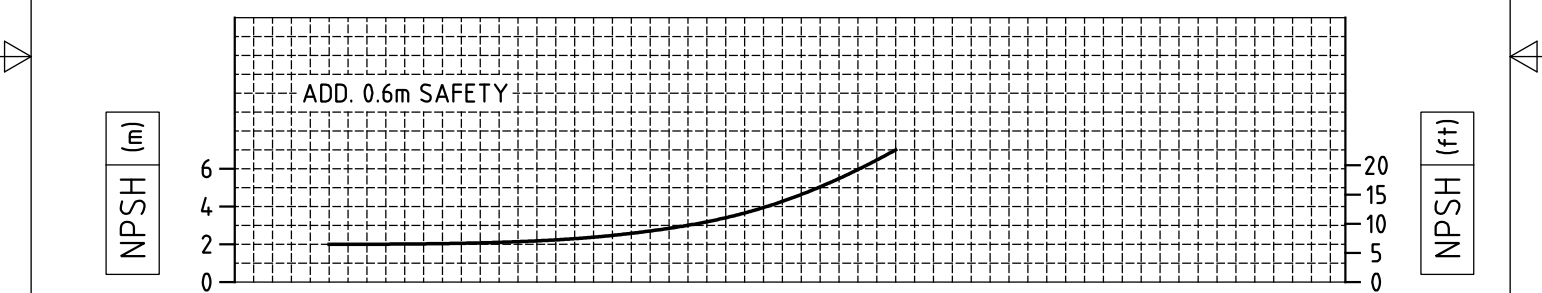
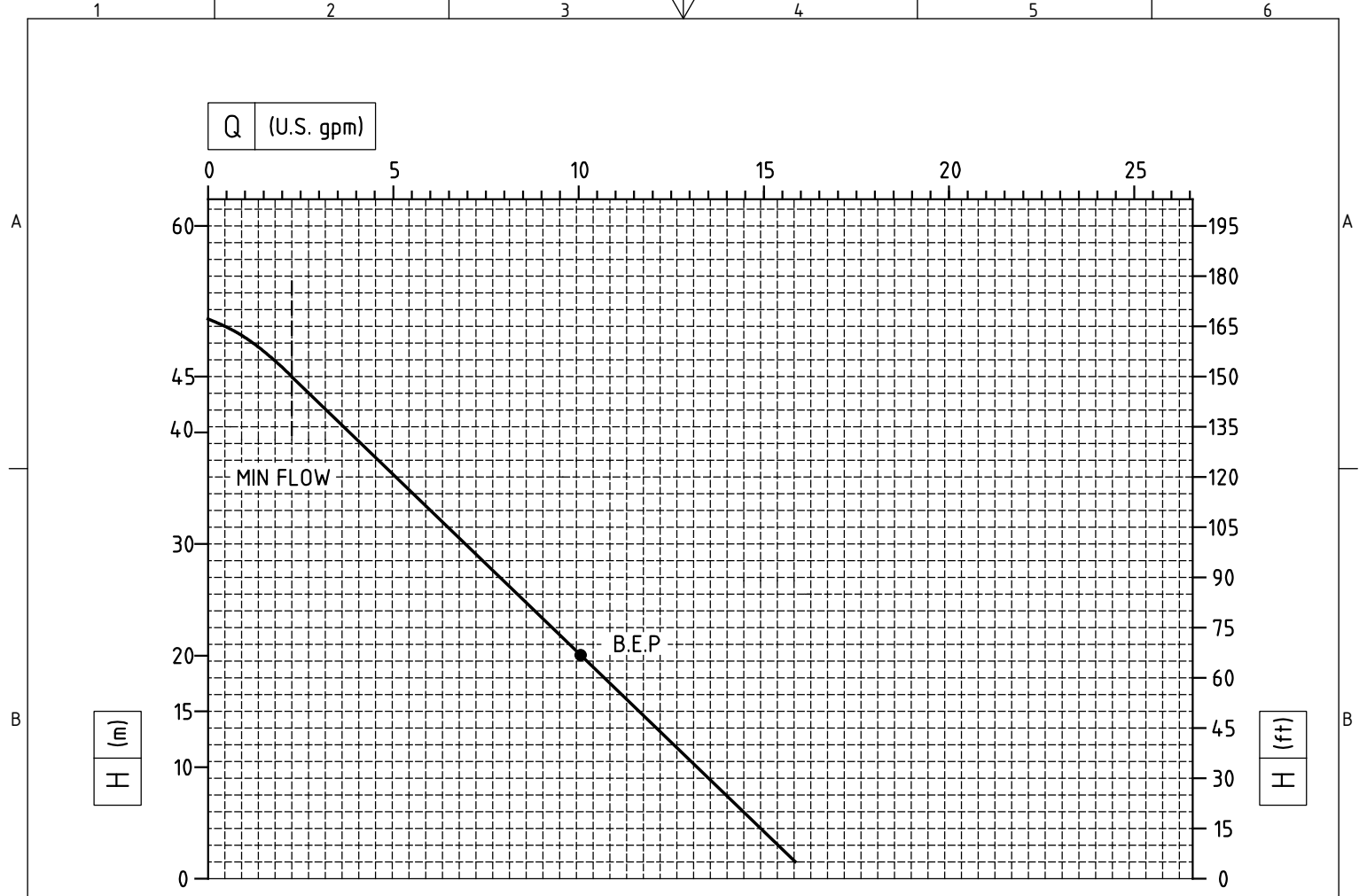

Motor power depends on specific gravity of pumped liquid.

 <p><b>MARCH PUMPEN GmbH &amp; Co.KG</b>          Rathenastraße 2          D-35394 Gießen  <a href="http://www.march-pumpen.com">www.march-pumpen.com</a>  <a href="mailto:info@march-pumpen.com">info@march-pumpen.com</a></p>	Baureihe / Series:	MTA
	Typ / Type:	MTA37
	Motor:	2900 1/min (50 Hz)



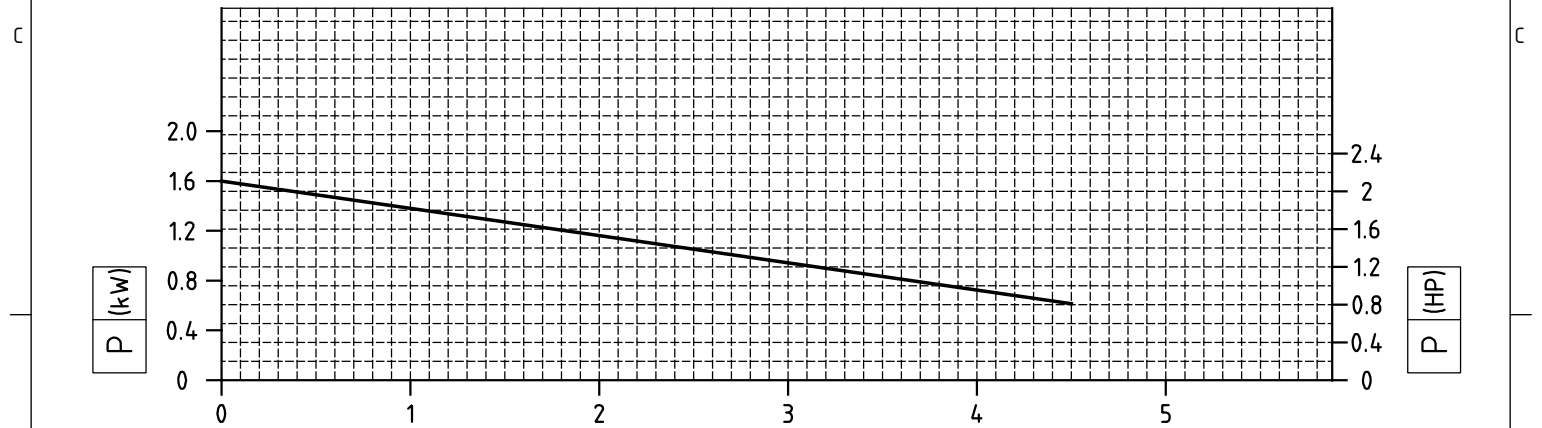
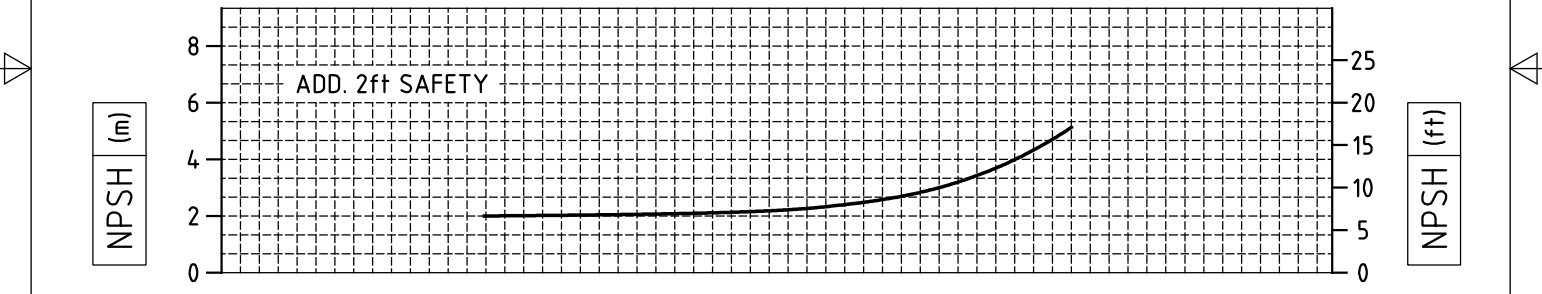
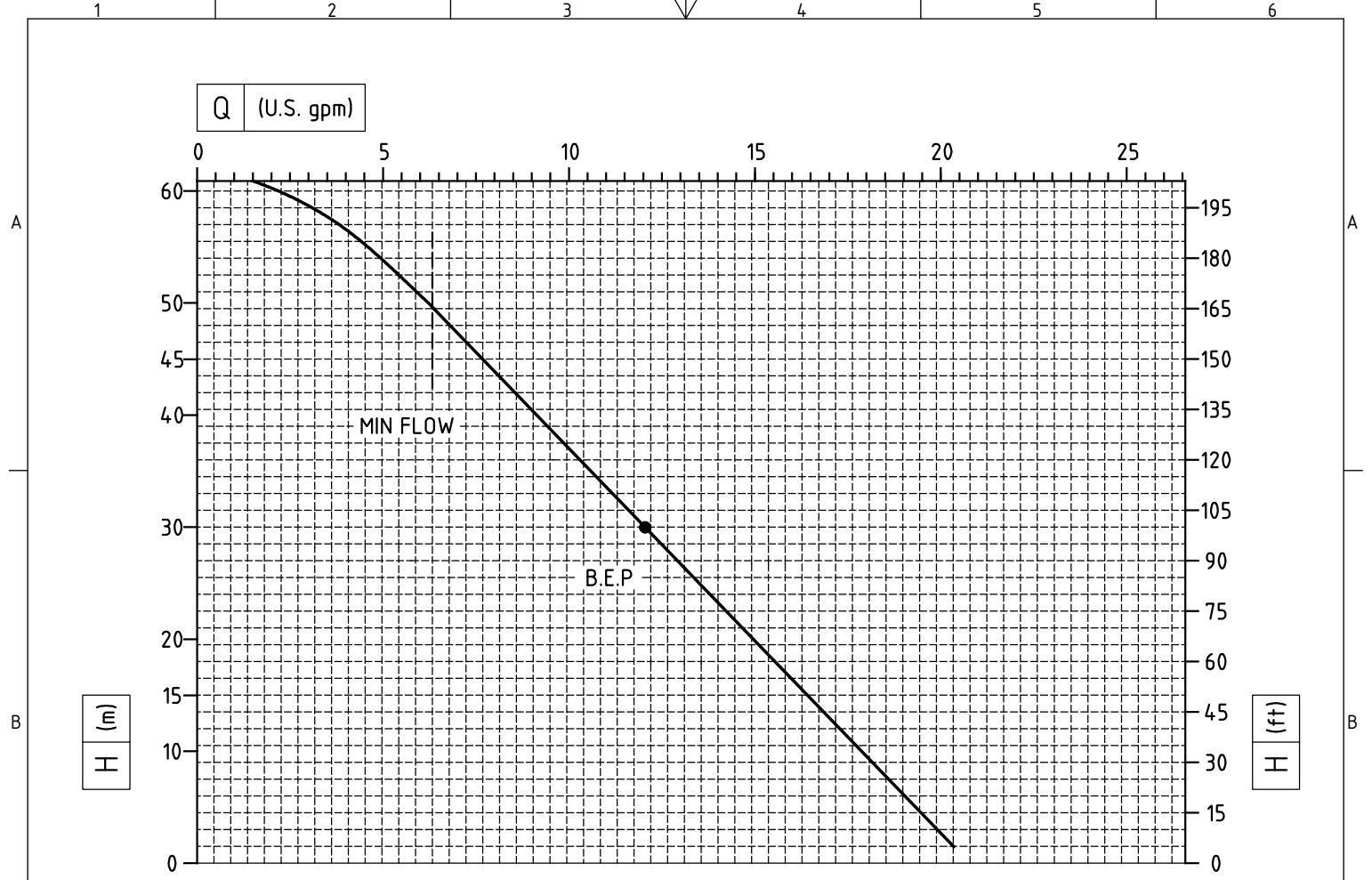



Q (m³/h)

- Motor power depends on specific gravity of pumped liquid.
- IEC motor power has been calculated considering 440V, for different voltage consult the factory.

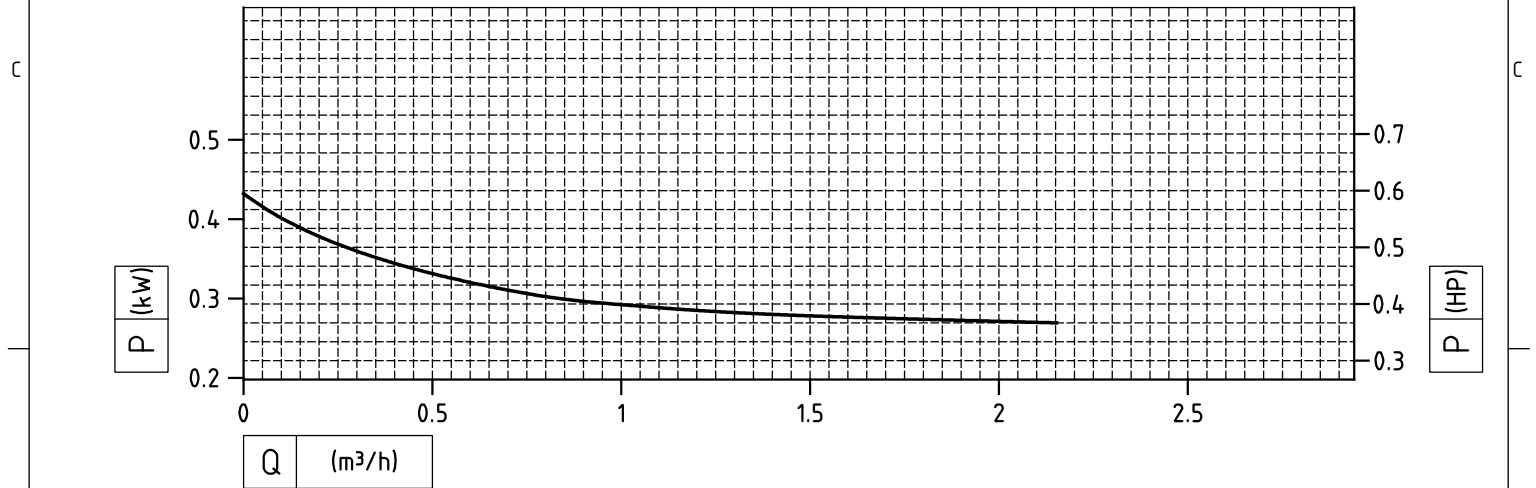
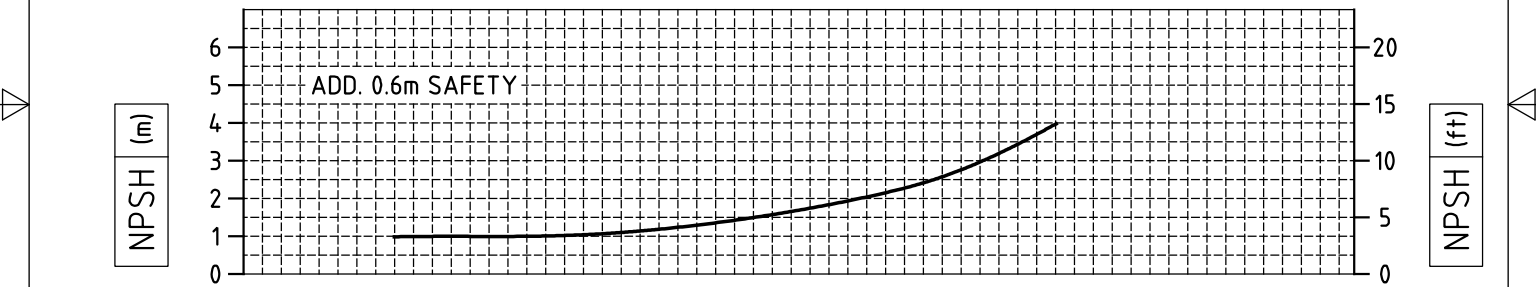
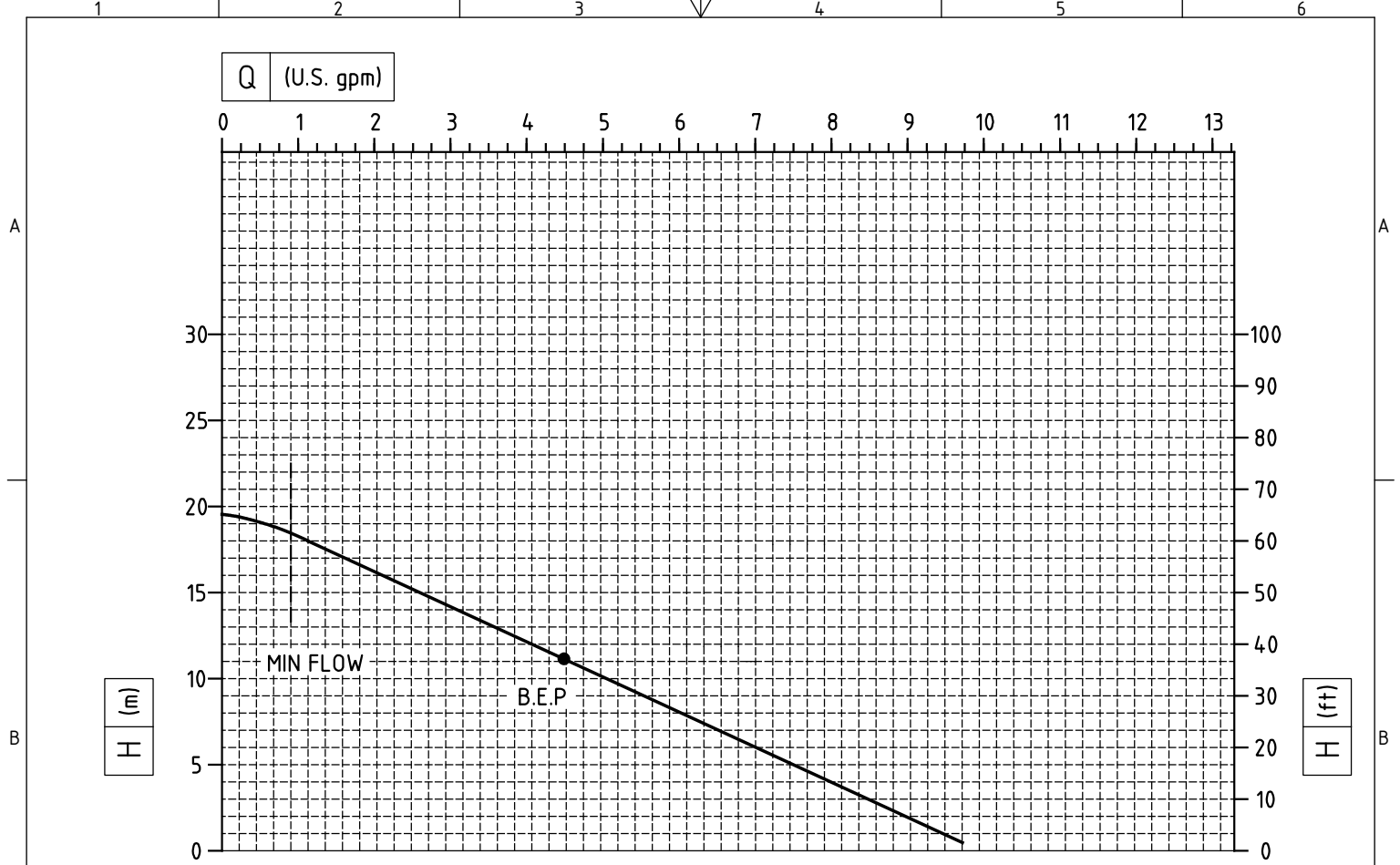
 <p><b>MARCH PUMPEN GmbH &amp; Co.KG</b>  Rathenastraße 2  D-35394 Gießen</p> <p>www.march-pumpen.com  info@march-pumpen.com</p>	Baureihe / Series:	MTA
	Typ / Type:	MTA 37
	Motor:	3500 1/min (60Hz)



Motor power depends on specific gravity of pumped liquid.

 <b>MARCH PUMPEN GmbH &amp; Co.KG</b> Rathenastraße 2 D-35394 Gießen <a href="http://www.march-pumpen.com">www.march-pumpen.com</a> <a href="mailto:info@march-pumpen.com">info@march-pumpen.com</a> <small>...ADVANCED SOLUTIONS...</small>	Baureihe / Series:	MTA
	Typ / Type:	MTA 49
	Motor:	1450 1/min

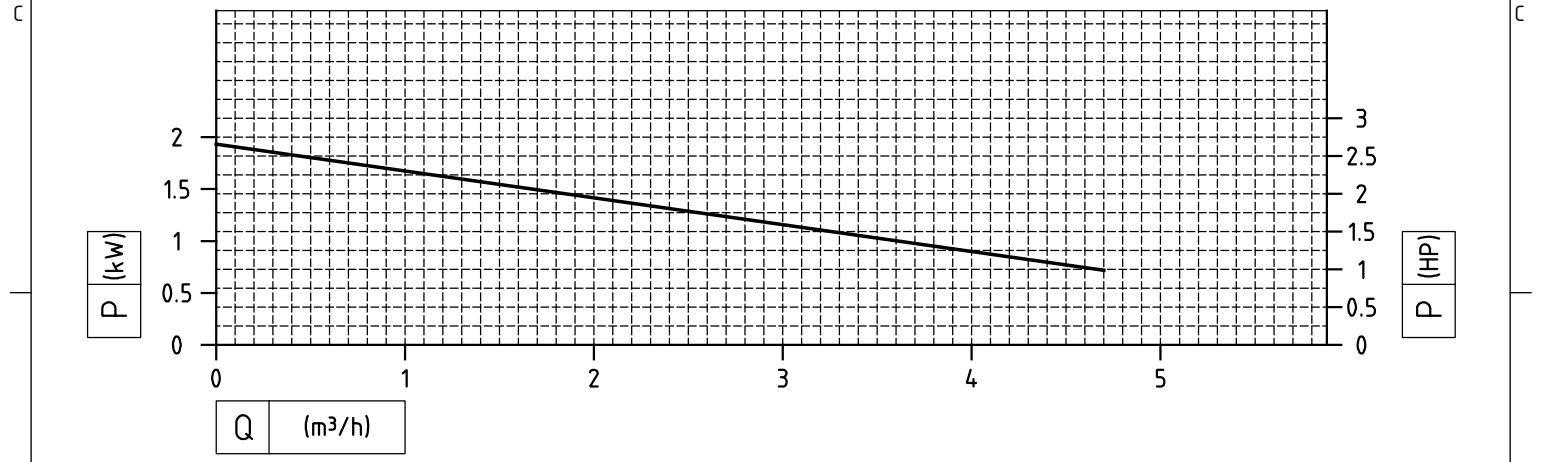
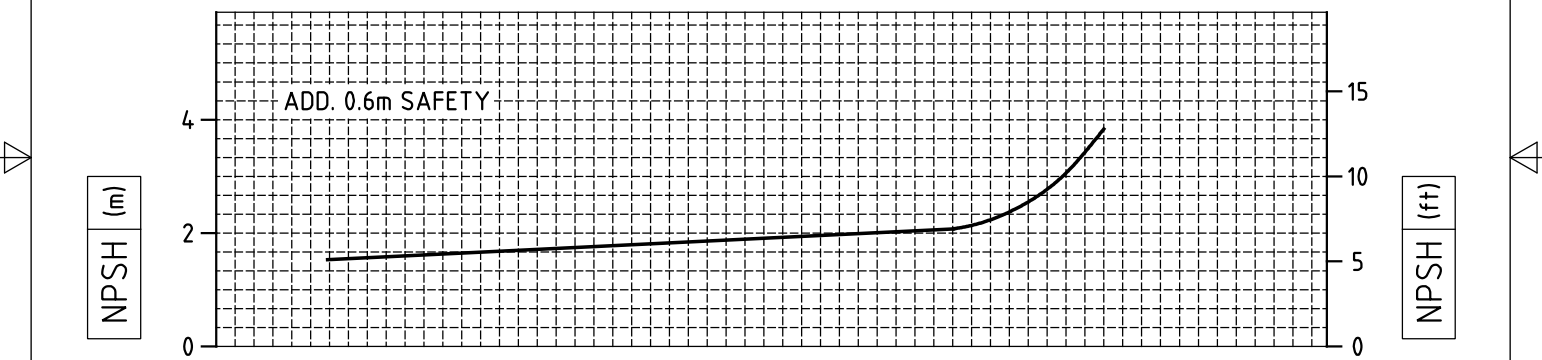
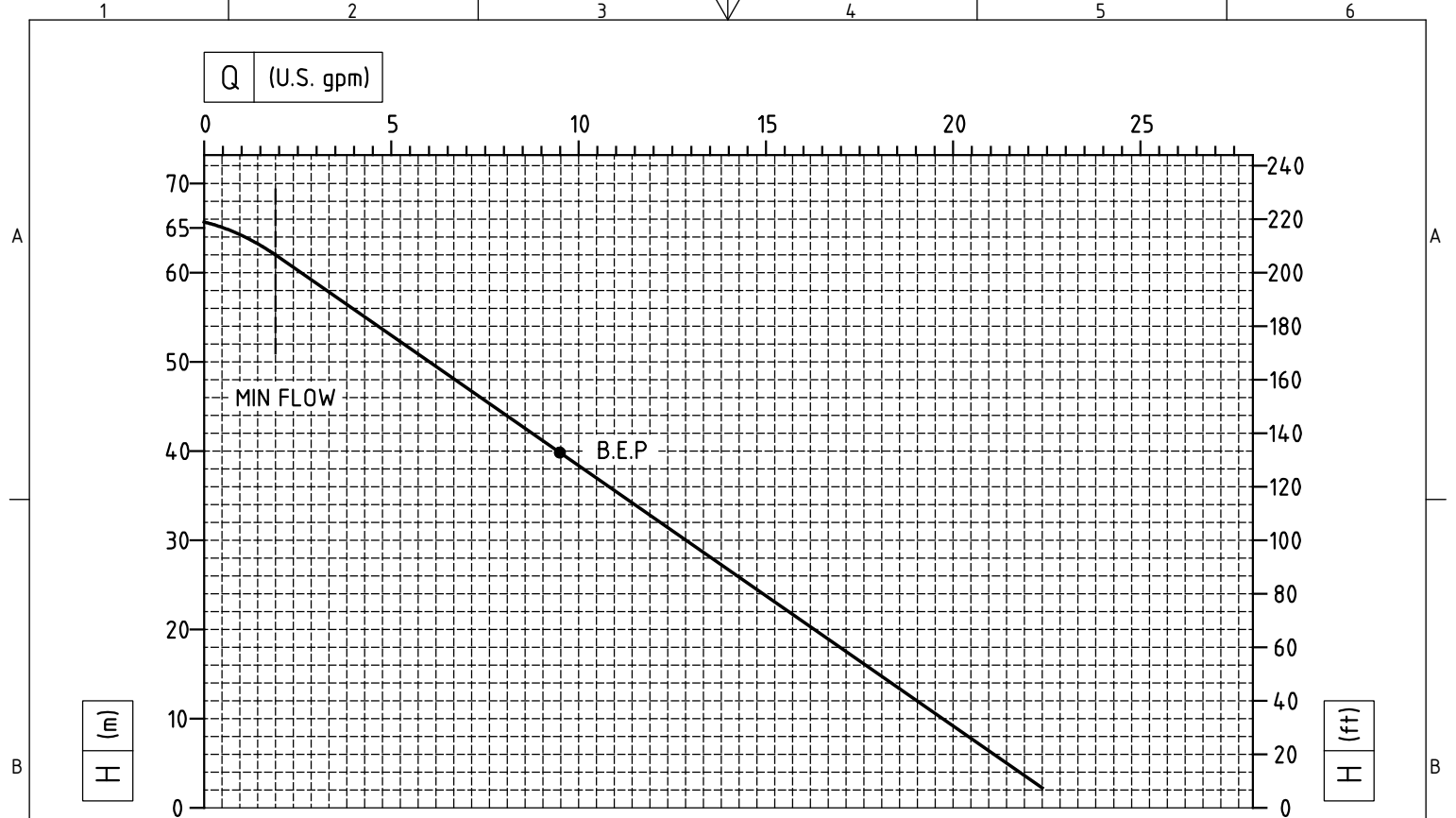

Motor power depends on specific gravity of pumped liquid.

 <b>MARCH PUMPEN GmbH &amp; Co.KG</b> Rathenastraße 2 D-35394 Gießen <a href="http://www.march-pumpen.com">www.march-pumpen.com</a> <a href="mailto:info@march-pumpen.com">info@march-pumpen.com</a> ...ADVANCED SOLUTIONS...	Baureihe / Series:	MTA
	Typ / Type:	MTA 49
	Motor:	2900 1/min

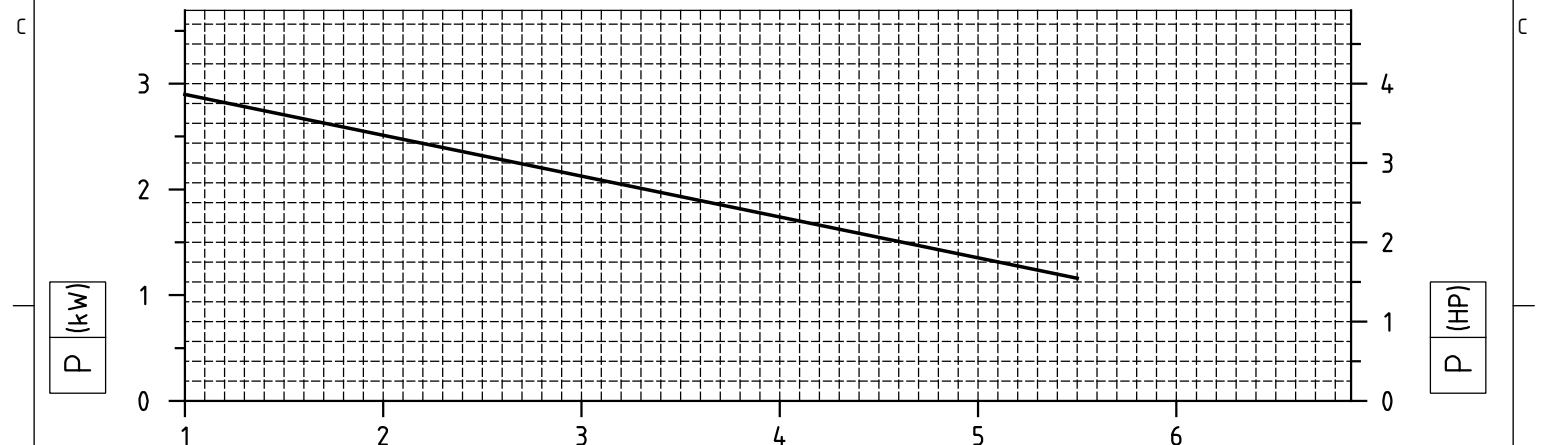
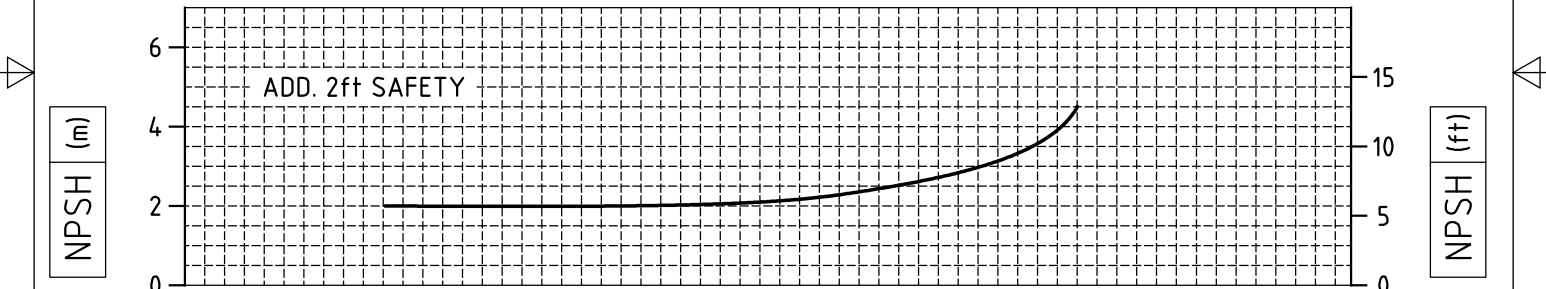
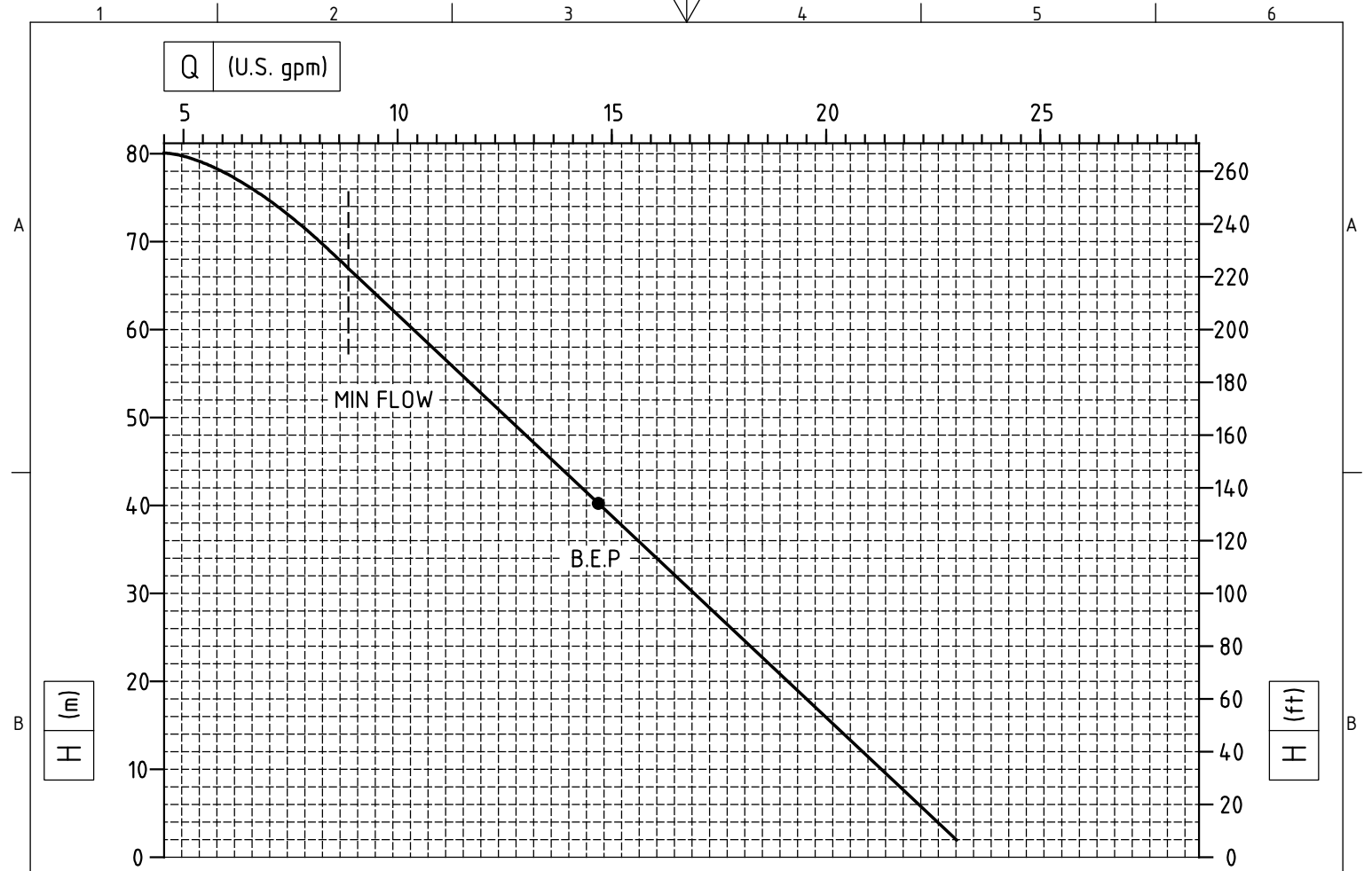



- Motor power depends on specific gravity of pumped liquid.  
 - IEC motor power has been calculated considering 440V,  
 for different voltage consult the factory.

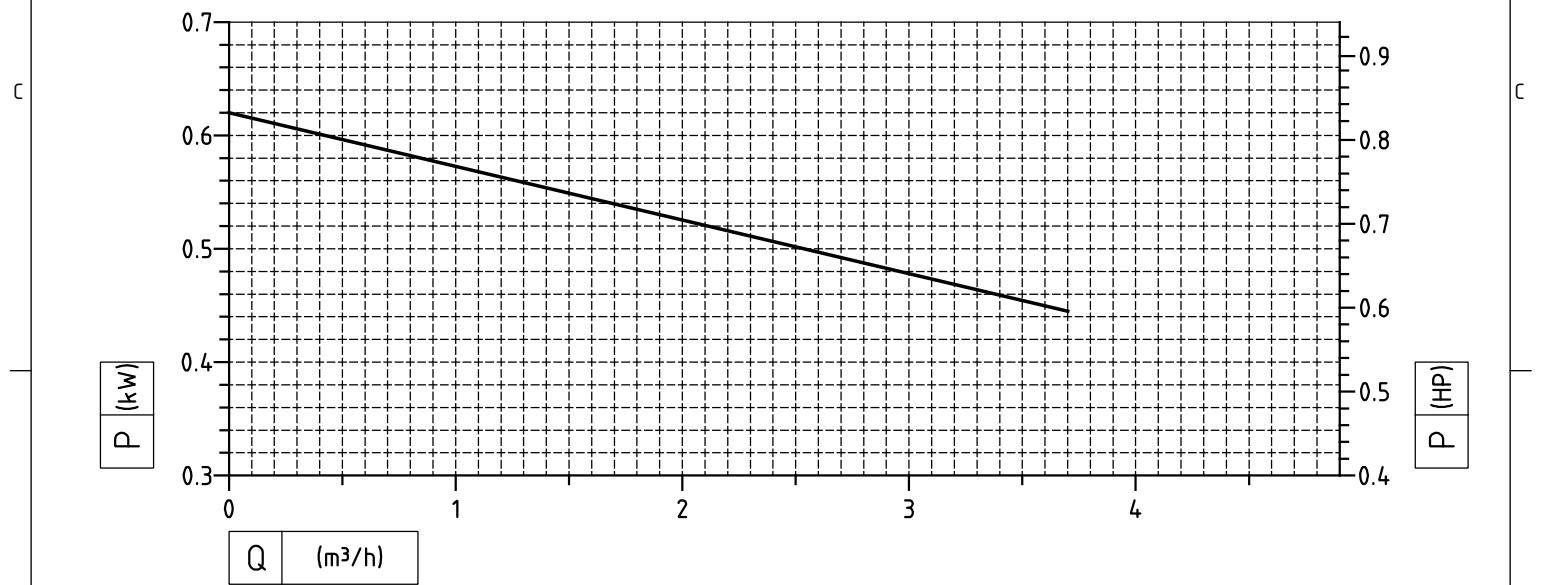
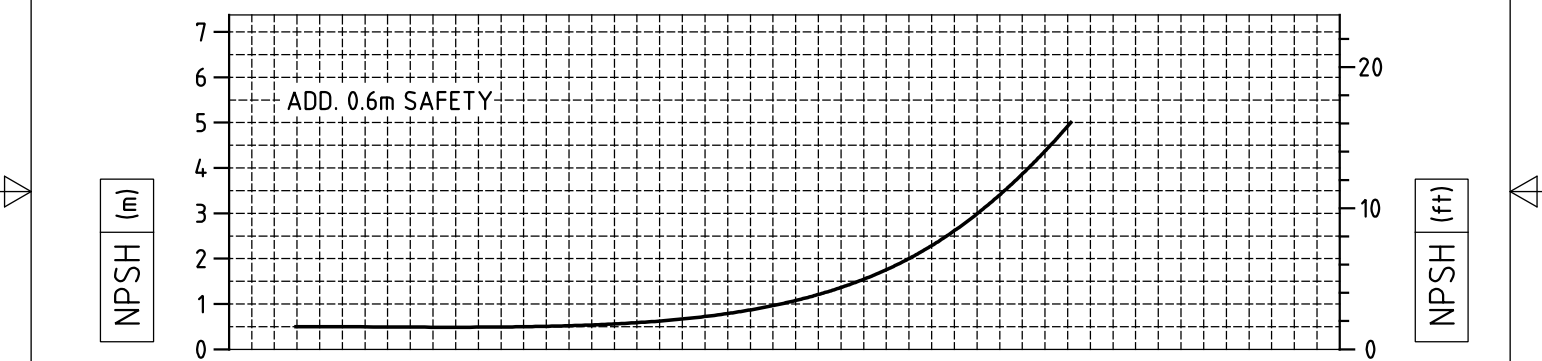
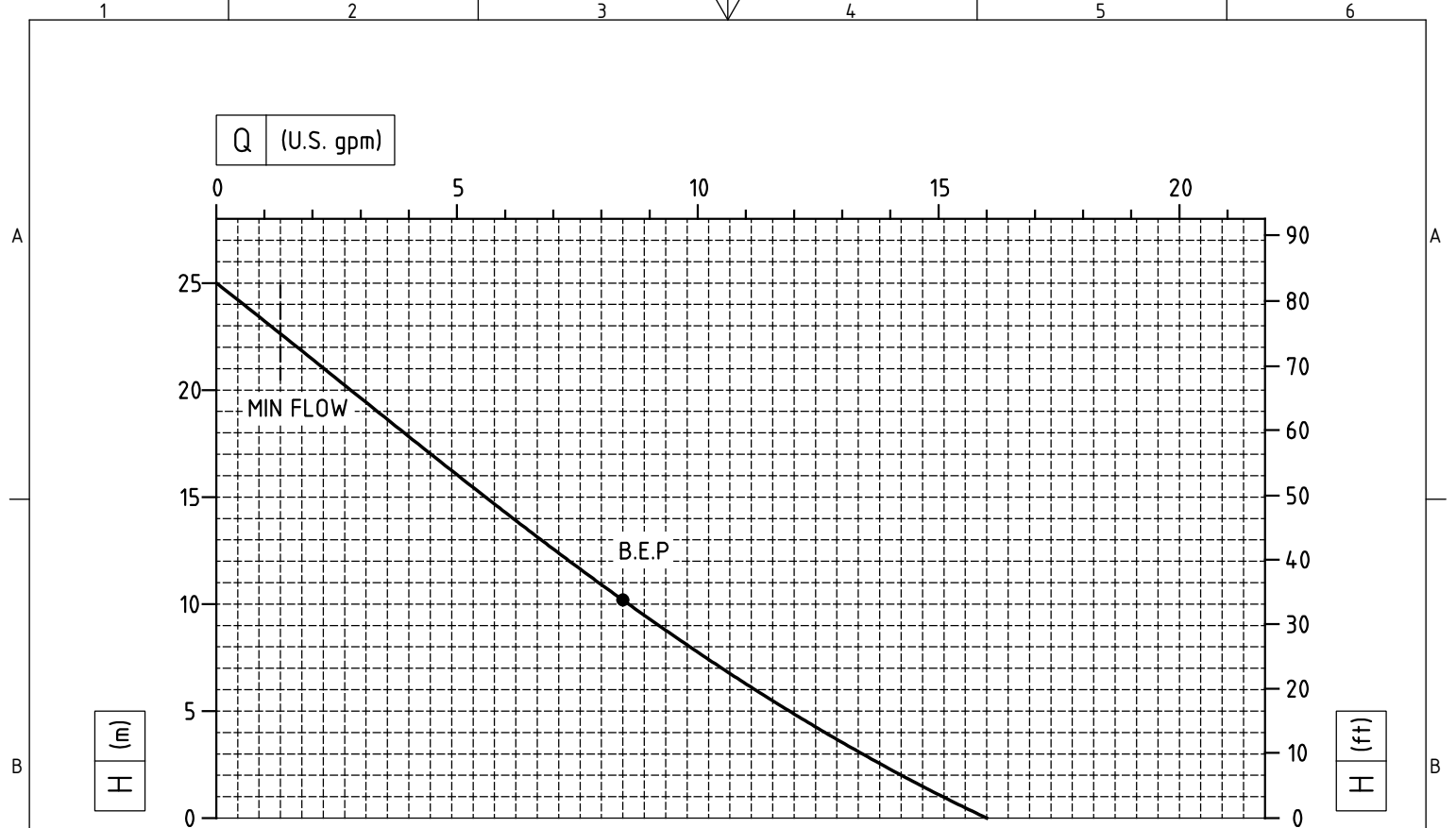

**MARCH PUMPEN GmbH & Co.KG**  
 Rathenastraße 2  
 D-35394 Gießen  
 www.march-pumpen.com  
 info@march-pumpen.com

Baureihe / Series:	MTA
Typ / Type:	MTA 49
Motor Speed:	3500 1/min



 <p><b>MARCH PUMPEN GmbH &amp; Co.KG</b>          Rathenastraße 2          D-35394 Gießen  <a href="http://www.march-pumpen.com">www.march-pumpen.com</a>  <a href="mailto:info@march-pumpen.com">info@march-pumpen.com</a></p>	Baureihe / Series:	MTA
	Typ / Type:	MTA 78
	Motor Speed:	1450 1/min



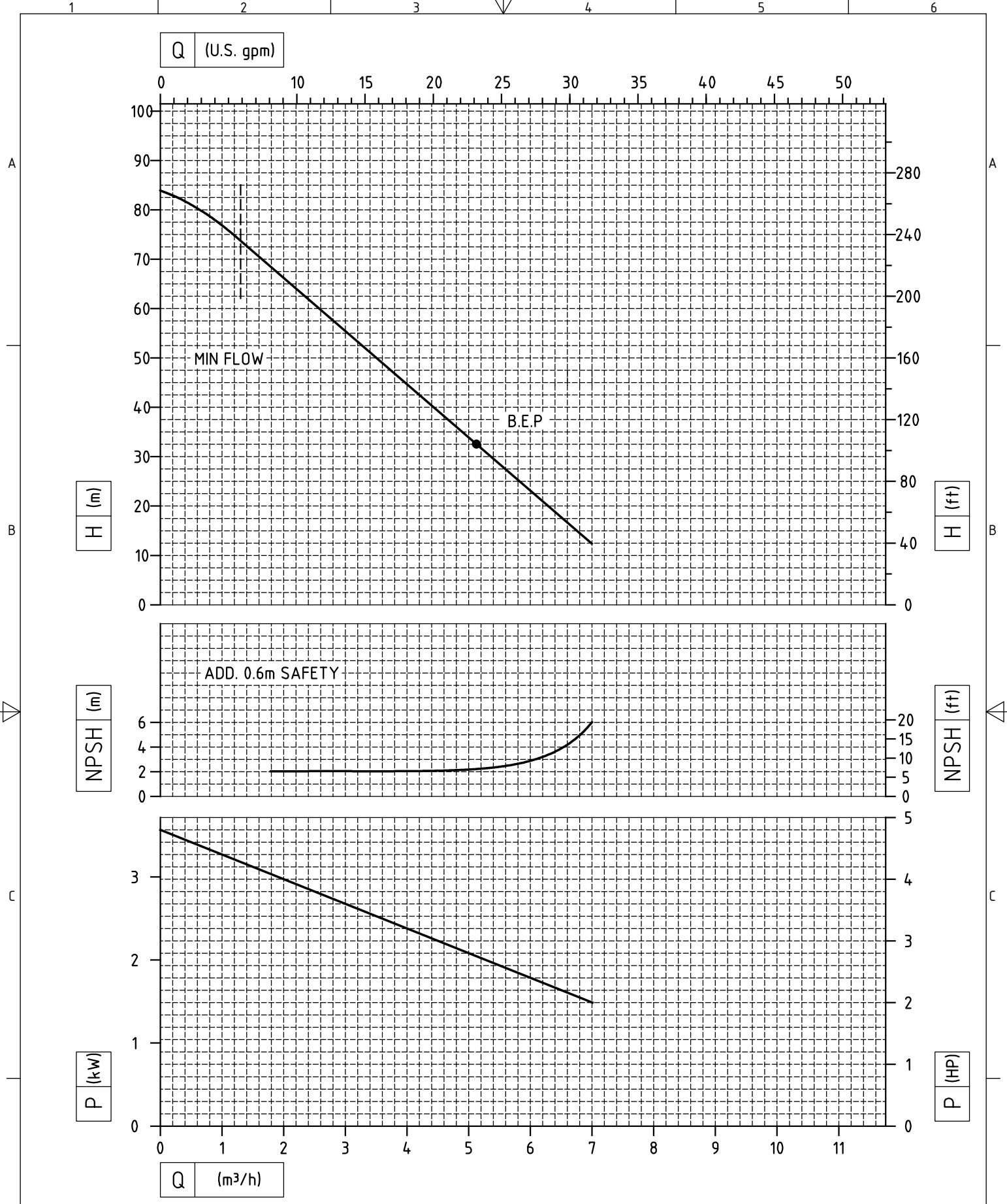

Motor power depends on specific gravity of pumped liquid.

 <p><b>MARCH PUMPEN GmbH &amp; Co.KG</b>  Rathenaustraße 2  D-35394 Gießen  www.march-pumpen.com  info@march-pumpen.com</p>	Baureihe / Series:	MTA
	Typ / Type:	MTA 78
	Motor:	2900 1/min

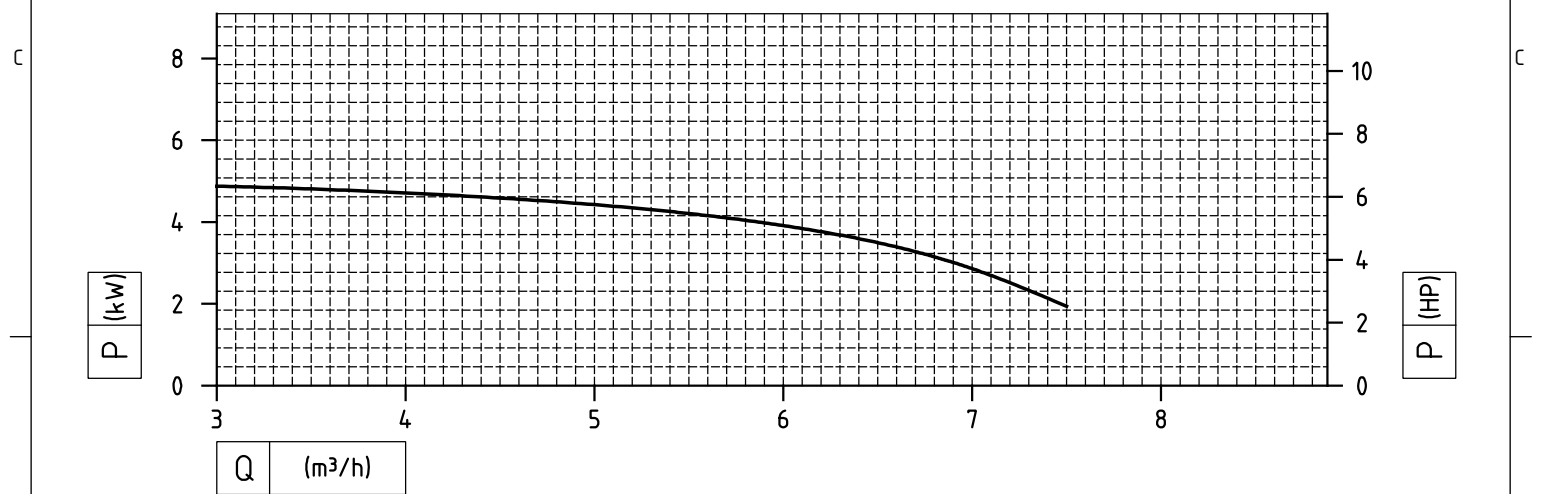
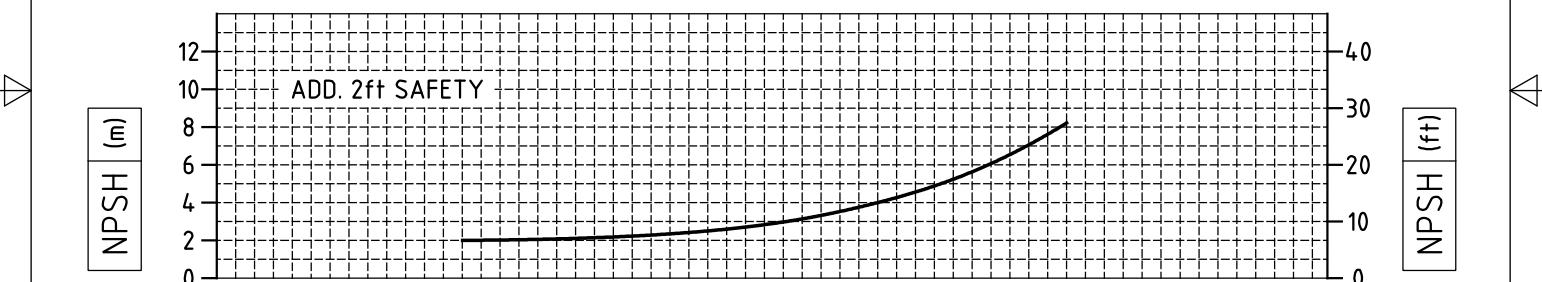
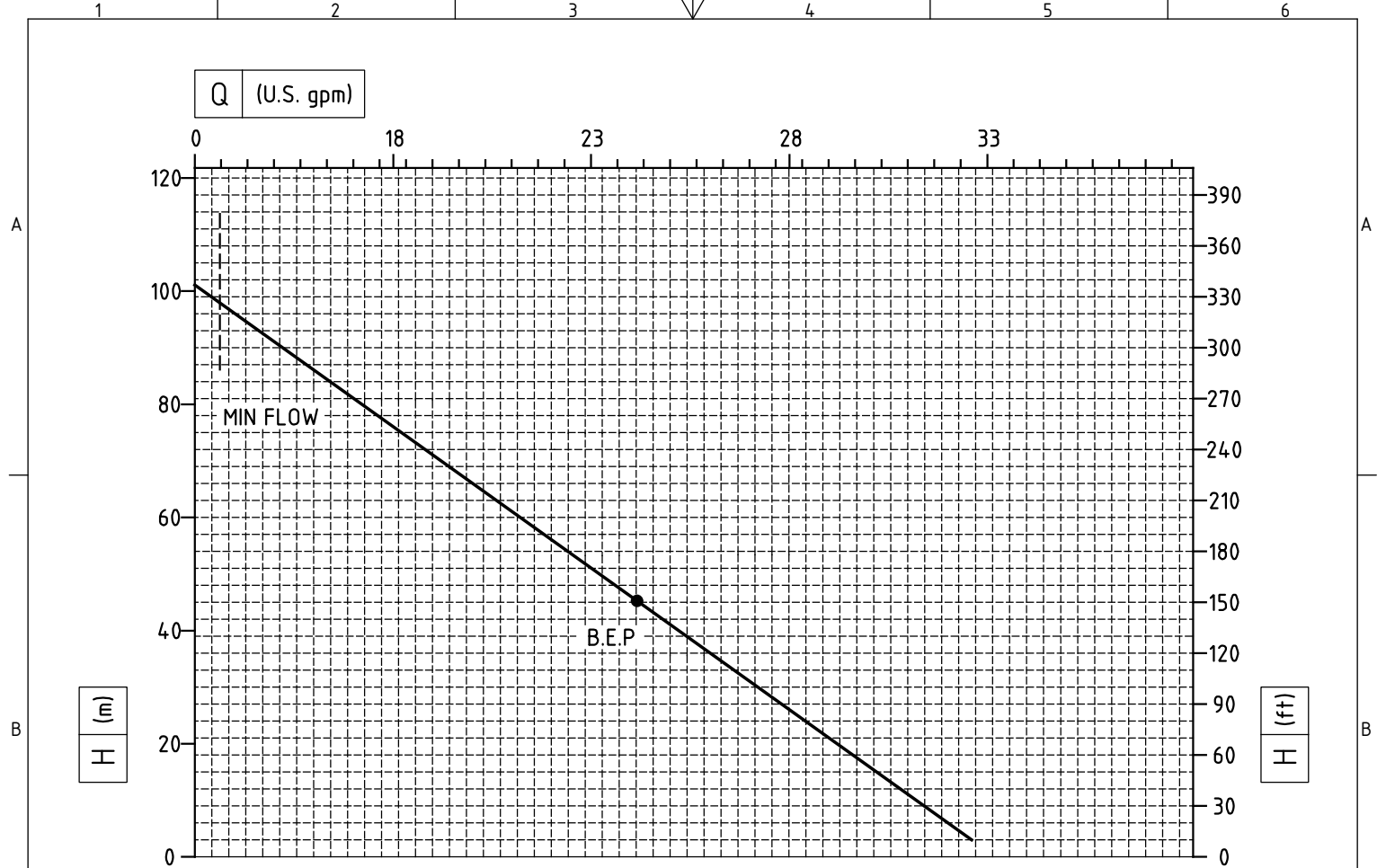

 <p><b>MARCH PUMPEN GmbH &amp; Co.KG</b>  Rathenaustraße 2  D-35394 Gießen  www.march-pumpen.com  info@march-pumpen.com</p>	Baureihe / Series:	MTA
	Typ / Type:	MTA 78
	Motor Speed:	3500 1/min

Q (U.S. gpm)

0 2 4 6 8 10 12 14 16 18 20 22 24 26

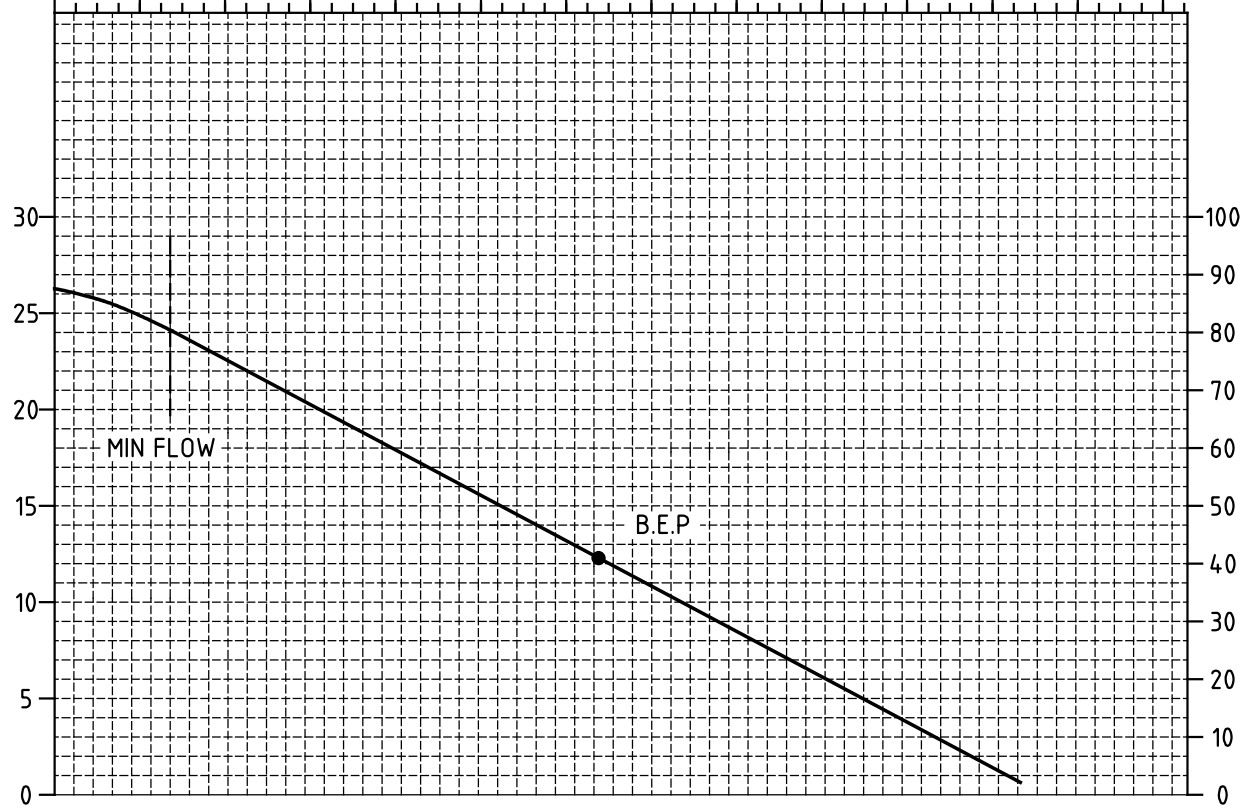

MIN FLOW

B.E.P.

H (m)

H (ft)

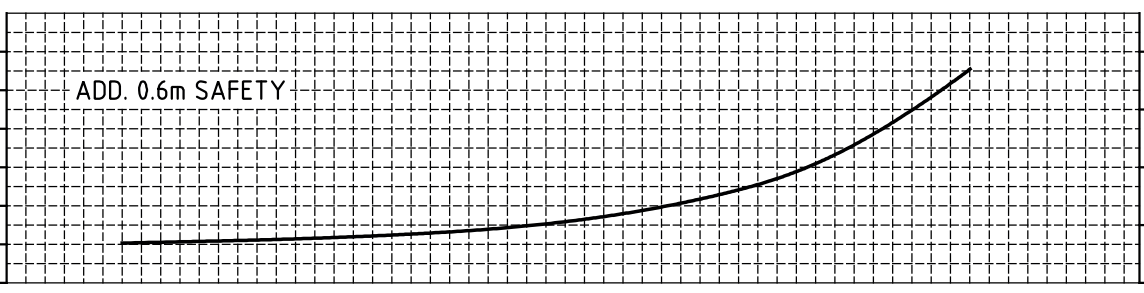

ADD. 0.6m SAFETY

NPSH (m)

NPSH (ft)

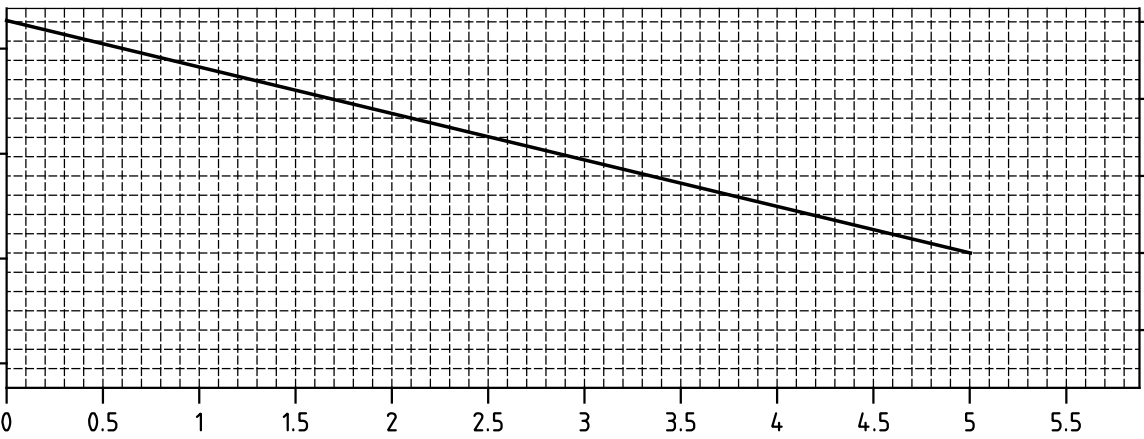

Q (m³/h)

P (kW)

P (HP)

Motor power depends on specific gravity of pumped liquid.



**MARCH PUMPEN GmbH & Co.KG**  
 Rathenastraße 2  
 D-35394 Gießen  
 www.march-pumpen.com  
 info@march-pumpen.com

Baureihe / Series:	MTA
Typ / Type:	MTA 1011
Motor Speed:	1450 1/min

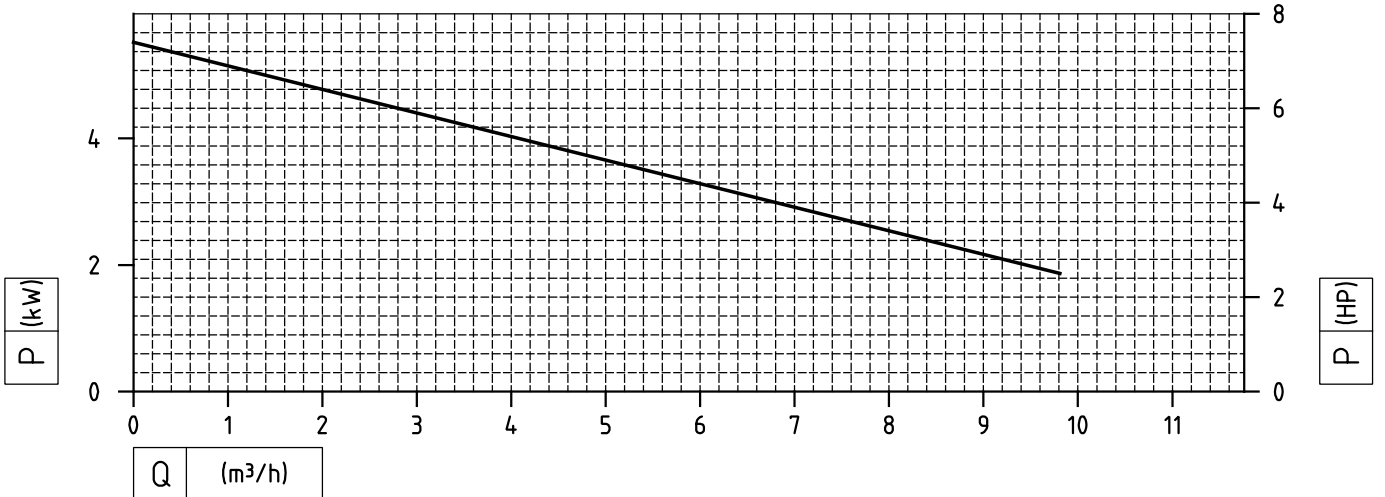
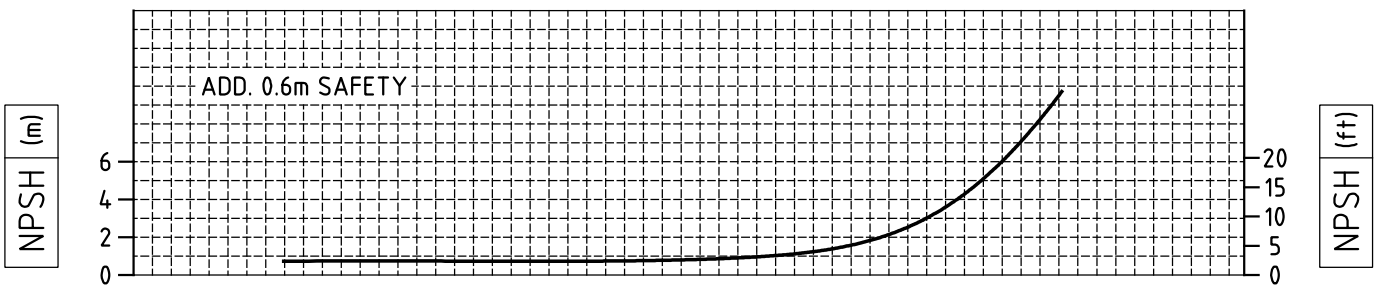
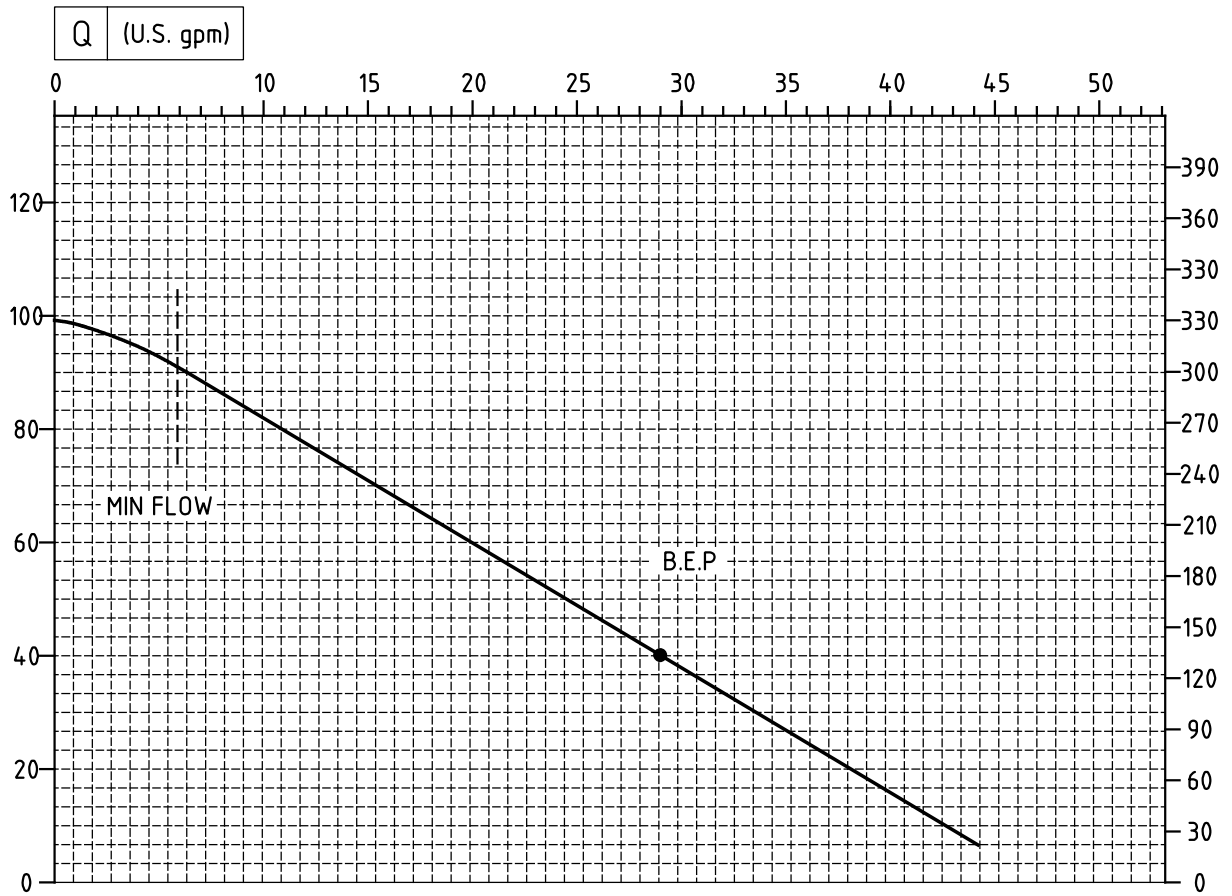

Motor power depends on specific gravity of pumped liquid.



**MARCH PUMPEN GmbH & Co.KG**  
 Rathenastraße 2  
 D-35394 Gießen  
 www.march-pumpen.com  
 info@march-pumpen.com

Baureihe / Series:	MTA
Typ / Type:	MTA 1011
Motor:	2900 1/min

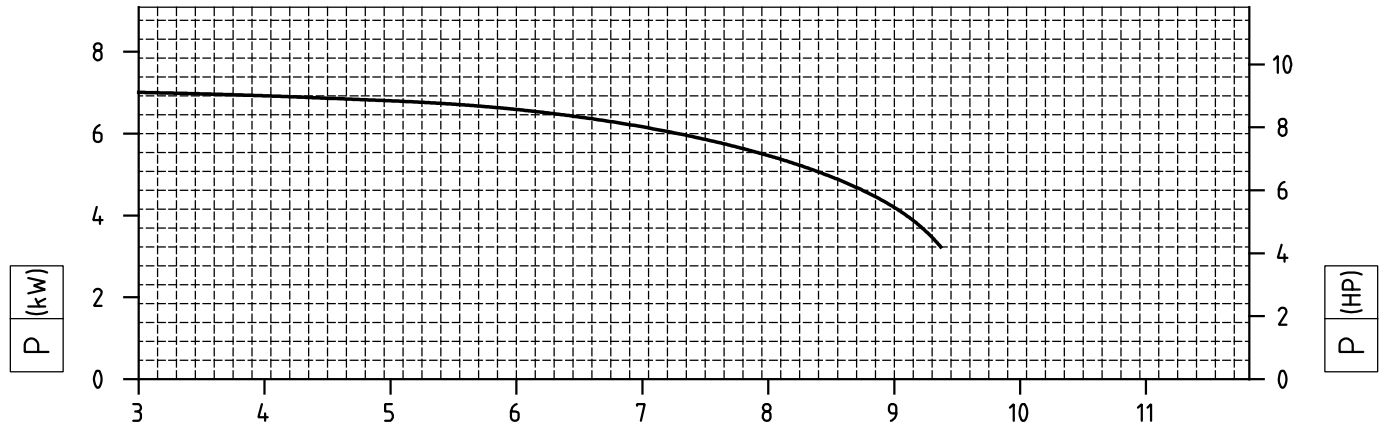
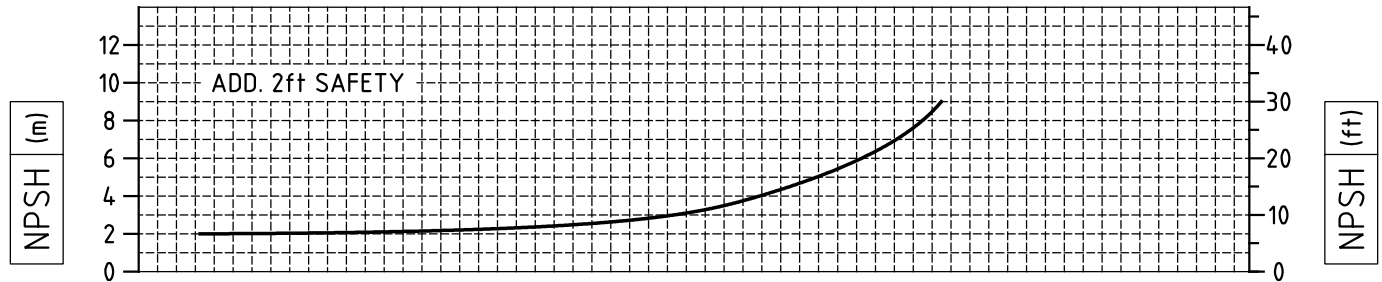
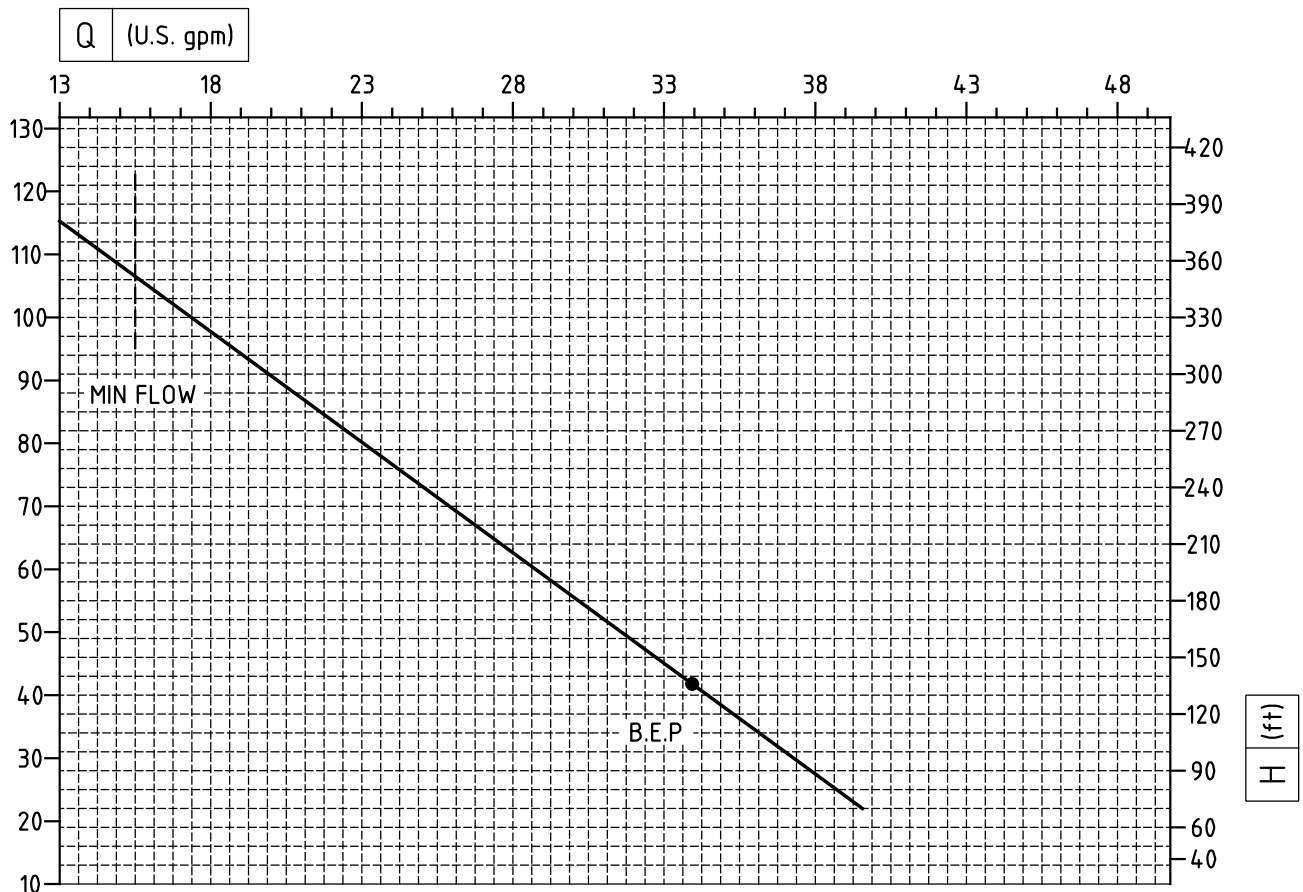

Q (m<sup>3</sup>/h)

- Motor power depends on specific gravity of pumped liquid.
- IEC motor power has been calculated considering 440V, for different voltage consult the factory.

 <p><b>MARCH PUMPEN GmbH &amp; Co.KG</b>          Rathenaustraße 2          D-35394 Gießen  <a href="http://www.march-pumpen.com">www.march-pumpen.com</a>  <a href="mailto:info@march-pumpen.com">info@march-pumpen.com</a></p>	Baureihe / Series:	MTA
	Typ / Type:	MTA 1011
	Motor:	3500 1/min (60Hz)



Q (U.S. gpm)

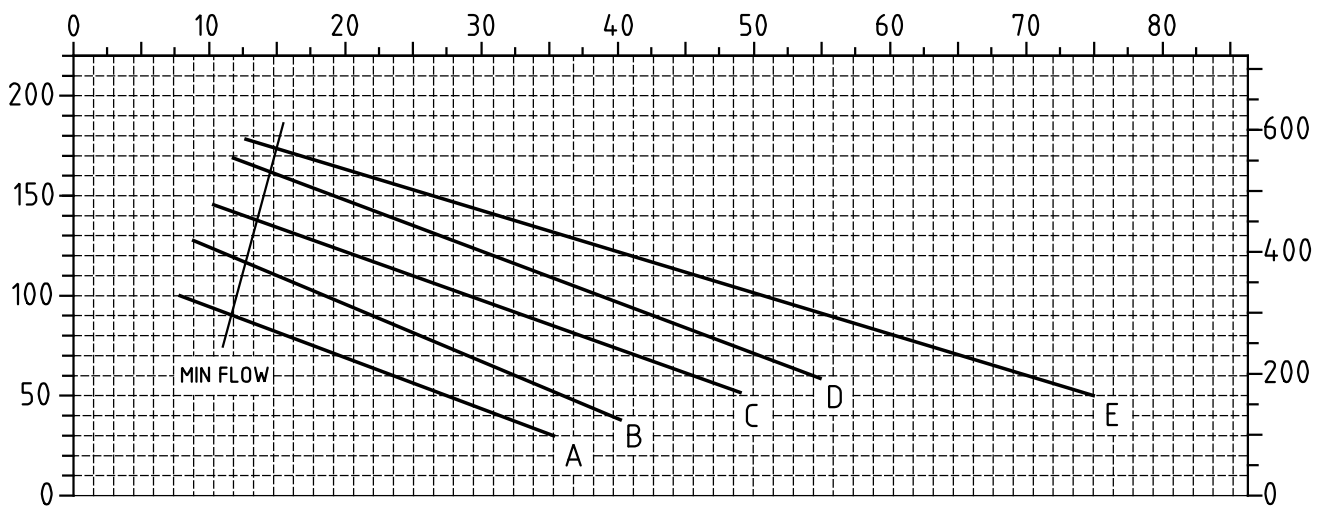

NPSH (m)

NPSH (ft)

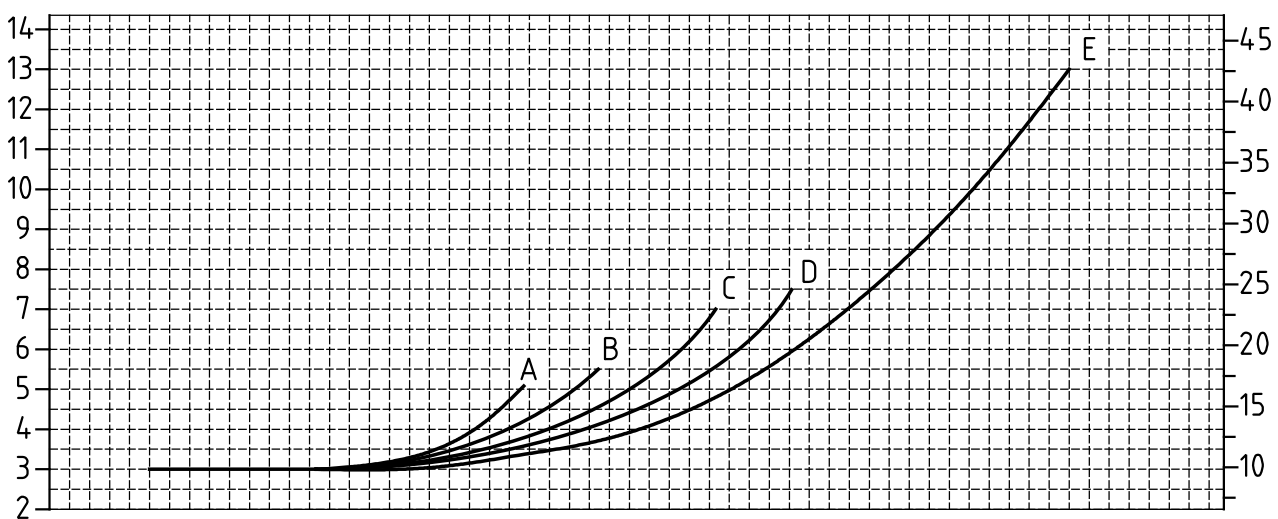

P (kW)

P (HP)

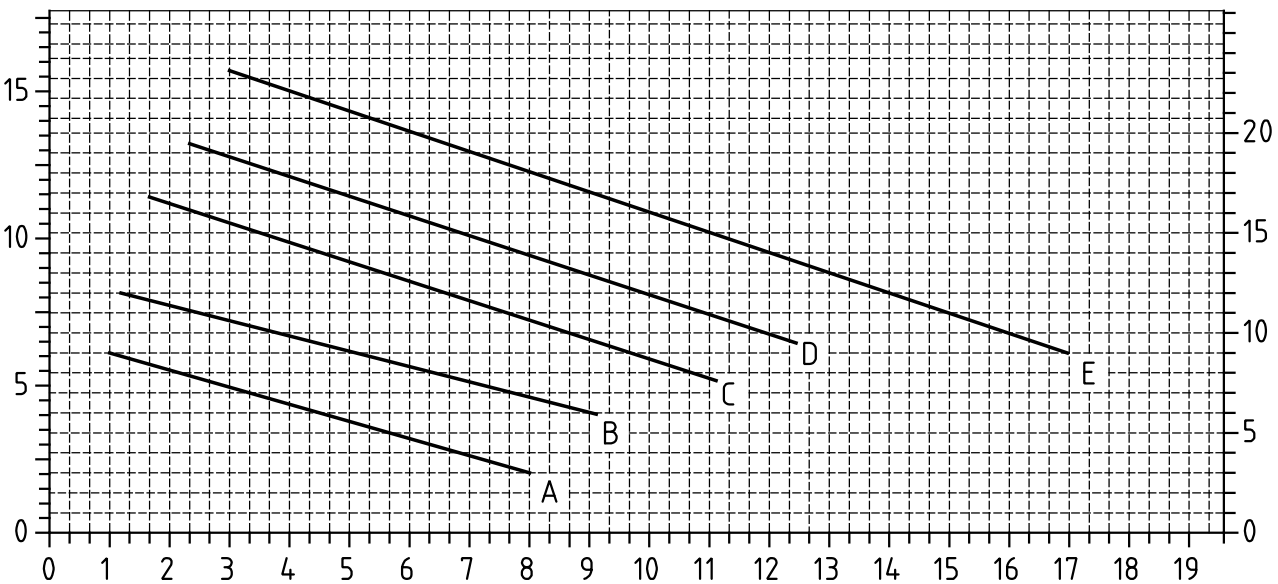

Q (m³/h)

Motor power depends on specific gravity of pumped liquid.



**MARCH PUMPEN GmbH & Co.KG**  
 Rathenaustraße 2  
 D-35394 Gießen  
 www.march-pumpen.com  
 info@march-pumpen.com

Baureihe / Series:	MTA
Typ / Type:	MTA 2020
Motor:	2900 1/min

dimensions in mm

A

B

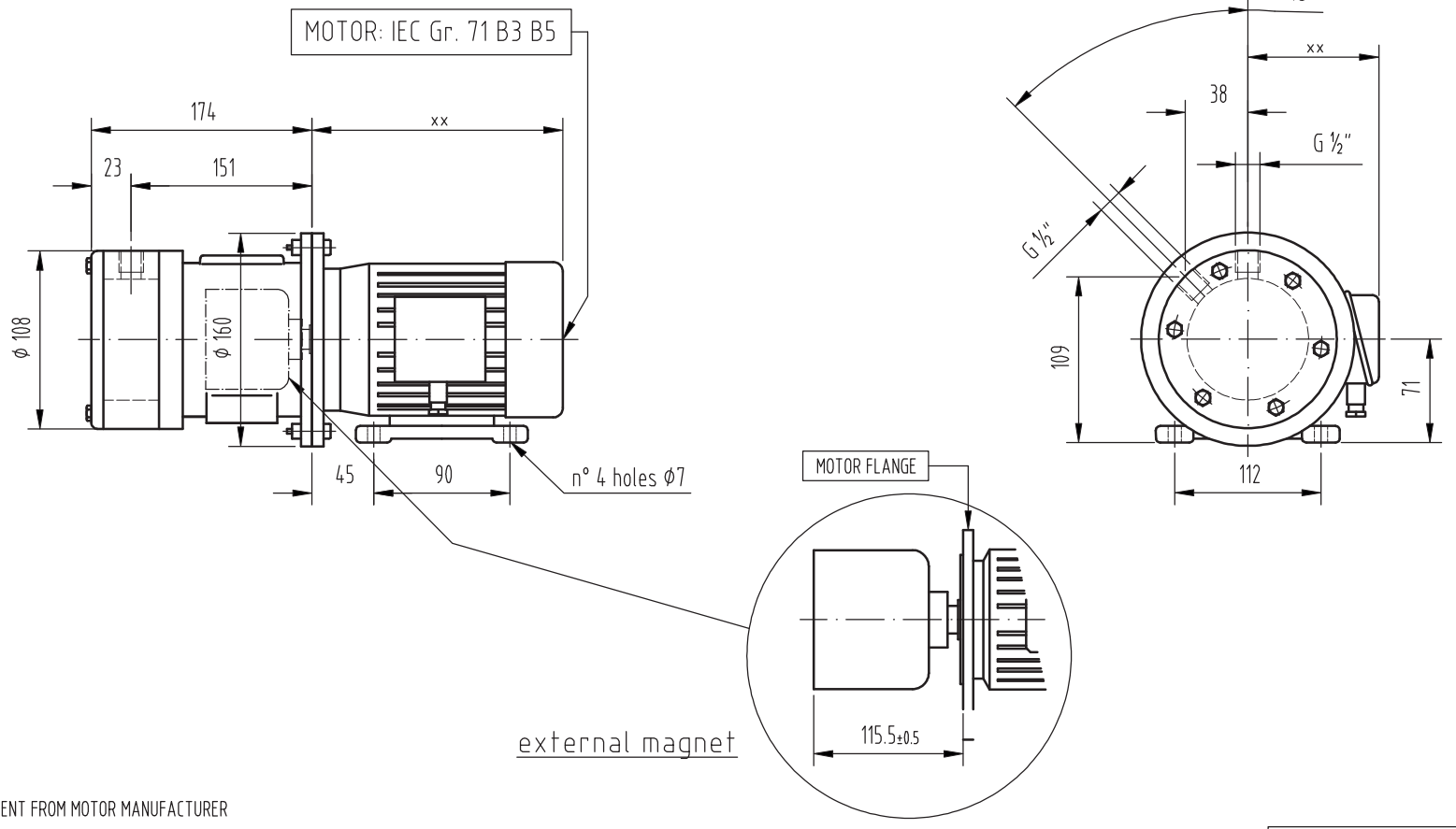

(x) DIFFERENT FROM MOTOR MANUFACTURER  
- DIRECTION AND PORTS LOCATION ARE REVERSIBLE

THREAD UNI ISO 228/1

REF	DESCRIPTION	MATERIAL	CODE
10	Containment shell	SS 316L	
20	Ext. Magnet	CoSm/ Carbon Steel	
30	Int. Magnet	SS 316L/CoSm	
40	Impeller	SS 316L	
50	Set O-Rings (a+b+c) a + b = O-Ring 4250 (230) c = O-Ring 4312 (235)	Viton	
61	Thrust Bearings	Pcarbon	
62	Rear Ring	SS316L	
70	Shaft	SIC	
75	Sleeve Bearings Bearings (d+e) Bearing (f)	SIC SS316	
78	Bracket (160-110-14)	Alluminium	
79	Rub Ring	Bronze	
84	End Cover	SS 316L	
85	Pump Casing	SS 316L	
88	Rear Wet End (10+30+40+50+61+62+70+75)	/	

C

D

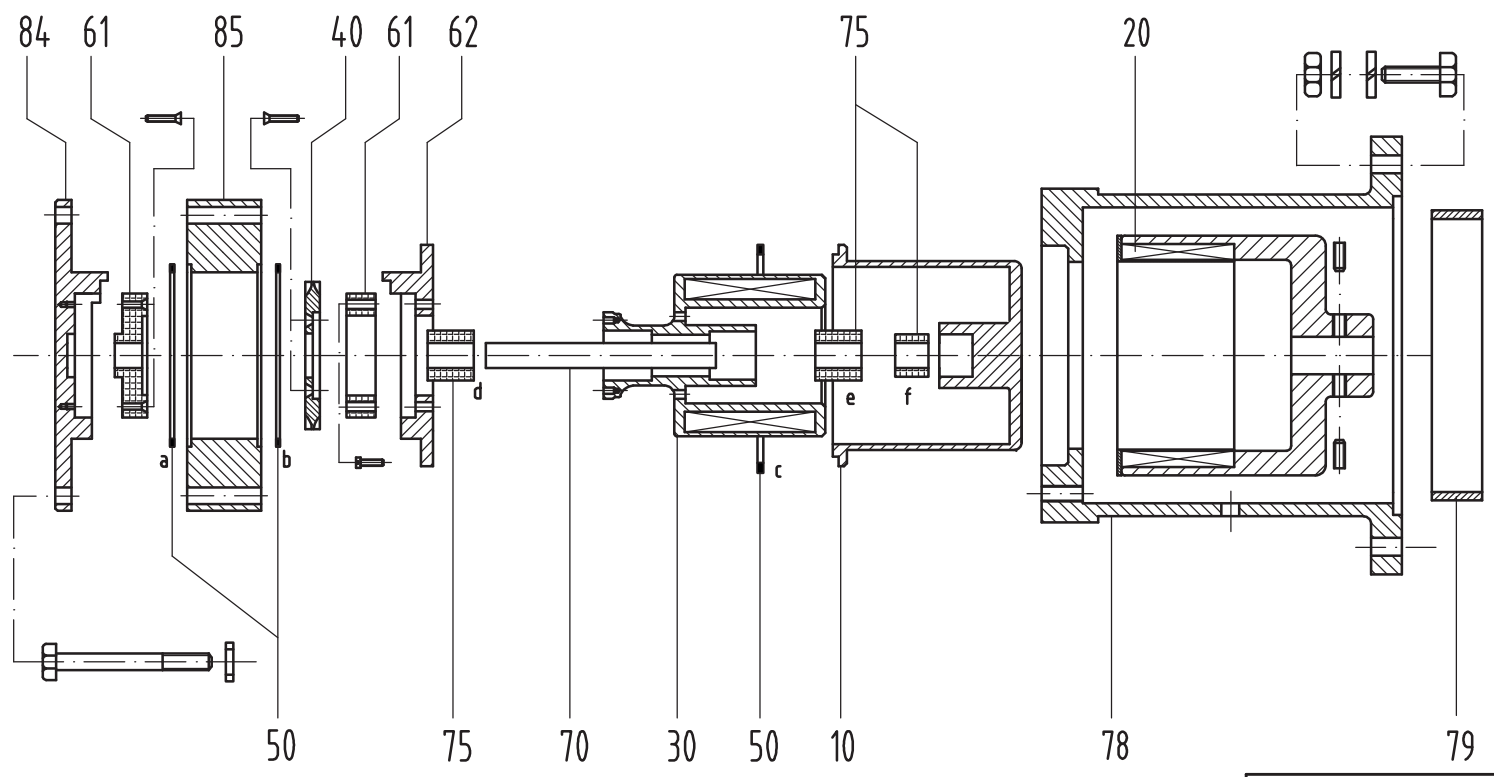

**MARCH PUMPEN GmbH & Co.KG**  
 Rathenastraße 2  
 D-35394 Gießen  
 www.march-pumpen.com  
 info@march-pumpen.com

Baureihe / Series:	MTA
Typ / Type:	MTA 25 SSR
Motor:	IEC 71 B35

1 | 2 | 3 | 4 | 5 | 6

dimensions in mm

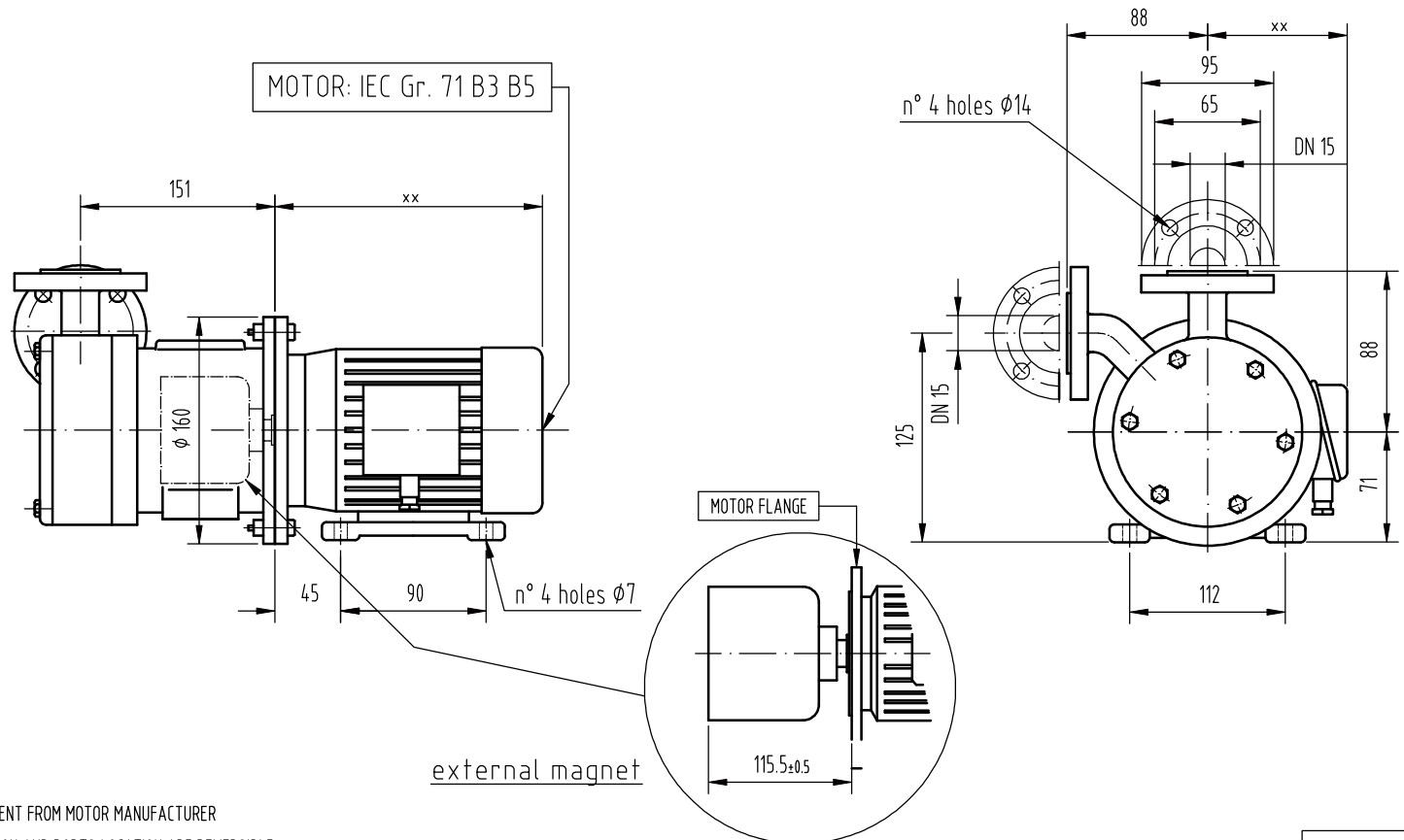

⊗ DIFFERENT FROM MOTOR MANUFACTURER  
- DIRECTION AND PORTS LOCATION ARE REVERSIBLE

FLANGED DIN 2633 PN 16

REF	DESCRIPTION	MATERIAL	CODE
10	Containment shell	SS 316L	
20	Ext. Magnet	CoSm/ Carbon Steel	
30	Int. Magnet	SS 316L/CoSm	
40	Impeller	SS 316L	
50	Set O-Rings (a+b+c) a + b = O-Ring 4250 (230) c = O-Ring 4312 (235)	Viton	
61	Thrust Bearings	Pcarbon	
62	Rear Ring	SS316L	
70	Shaft	SS316L	
75	Sleeve Bearings Bearings (d+e) Bearing (f)	Pcarbon SS316	
78	Bracket (160-110-14)	CAST IRON	
79	Rub Ring	Bronze	
84	End Cover	SS 316L	
85	Pump Casing	SS 316L	
88	Rear Wet End (10+30+40+50+61+62+70+75)	/	

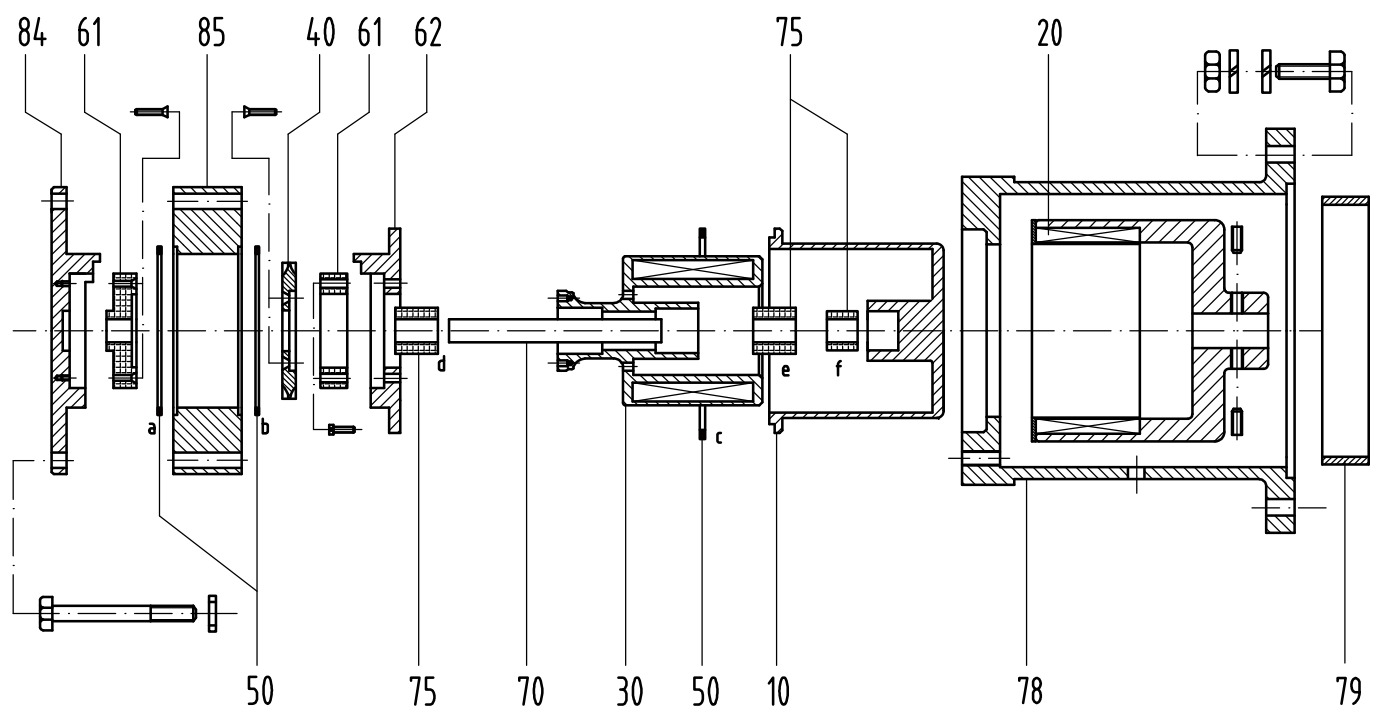

**MARCH PUMPEN GmbH & Co.KG**  
 Rathenastraße 2  
 D-35394 Gießen  
 www.march-pumpen.com  
 info@march-pumpen.com

Baureihe / Series:	MTA
Typ / Type:	MTA 25 SSF
Motor:	IEC 71 B35

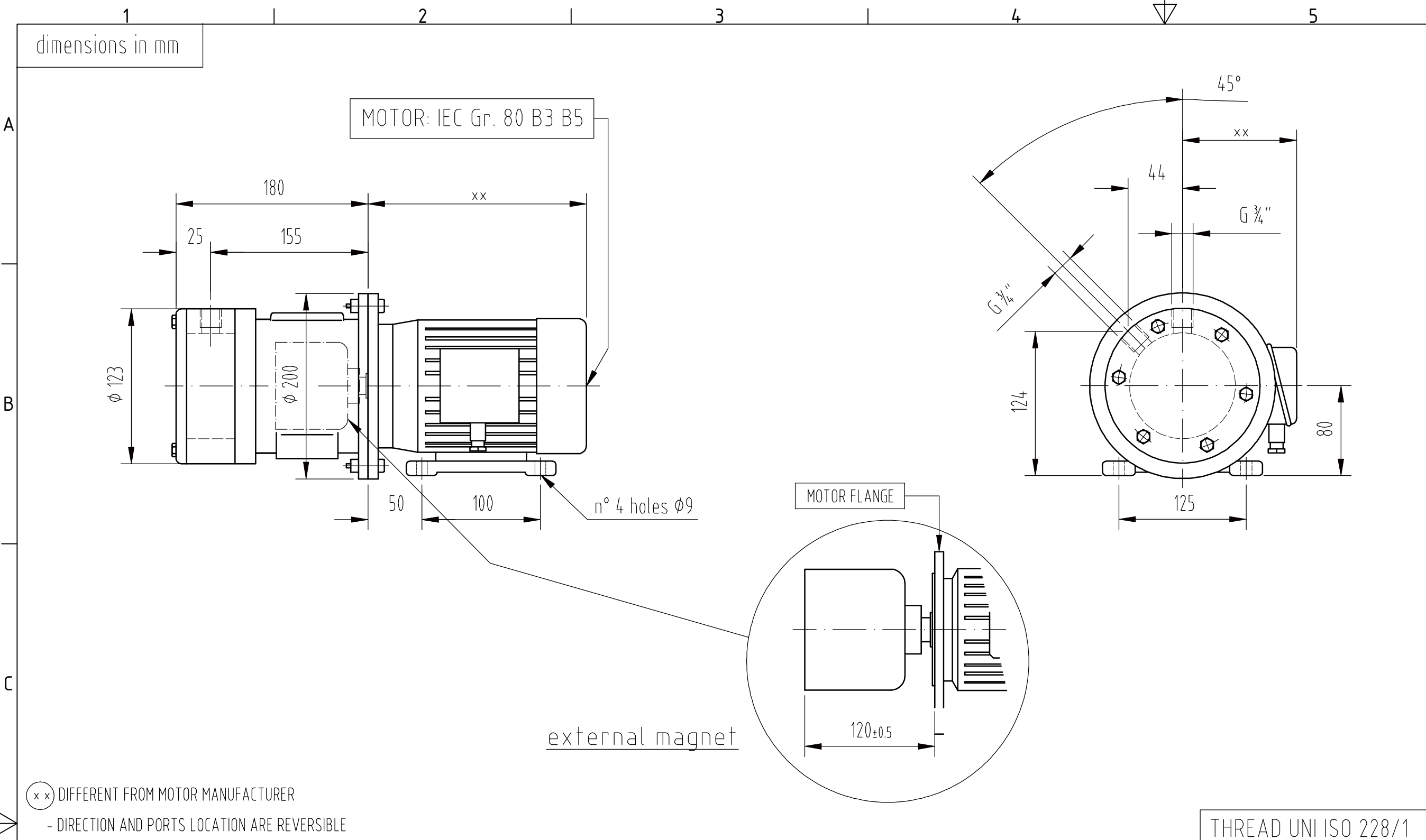

REF	DESCRIPTION	MATERIAL	CODE
10	Containment shell	SS 316L	
20	Ext. Magnet	CoSm/ Carbon Steel	
30	Int. Magnet	SS 316L/CoSm	
40	Impeller	SS 316L	
50	Set O-Rings (a+b+c) a + b = O-Ring 4300 (234) c = O-Ring 4362 (239)	Viton	
61	Thrust Bearings	Pcarbon	
62	Rear Ring	SS316L	
70	Shaft	SS316L	
75	Sleeve Bearings Bearings (d+e) Bearing (f)	Pcarbon SS316	
78	Bracket (200-130-19)	Alluminium	
79	Rub Ring	Bronze	
84	End Cover	SS 316L	
85	Pump Casing	SS 316L	
88	Rear Wet End (10+30+40+50+61+62+70+75)	/	

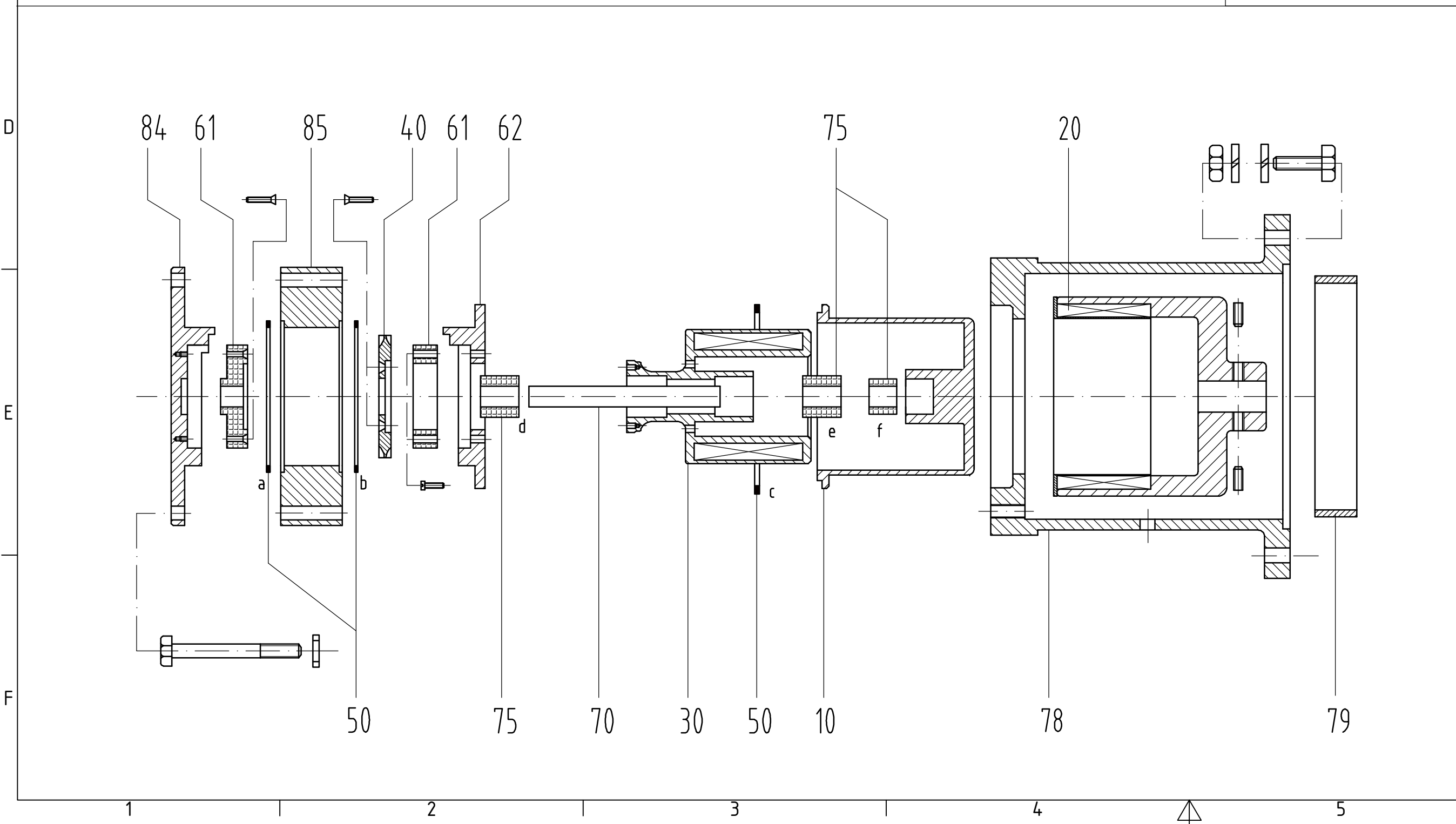

Alle Angaben unverbindlich, technische Änderungen vorbehalten! Technical data not binding and subject to change!  
Copyright MARCH PUMPEN GmbH & Co.KG 2019

	MARCH PUMPEN GmbH & Co.KG Rälthausstraße 2 D-35394 Gießen info@march-pumpen.com www.march-pumpen.com			Allgemeintoleranzen nach DIN ISO 2768-m Alle Kanten gratfrei	
	Datum: 02.07.2019 Name: Lach			Series MTA MTA 37 SSR	
	Gezeichnet: / Kontrolliert: / Norm: /			DPCA-0037-R	
	Status: / Änderungen: / Datum: / Name: /			1 A2	

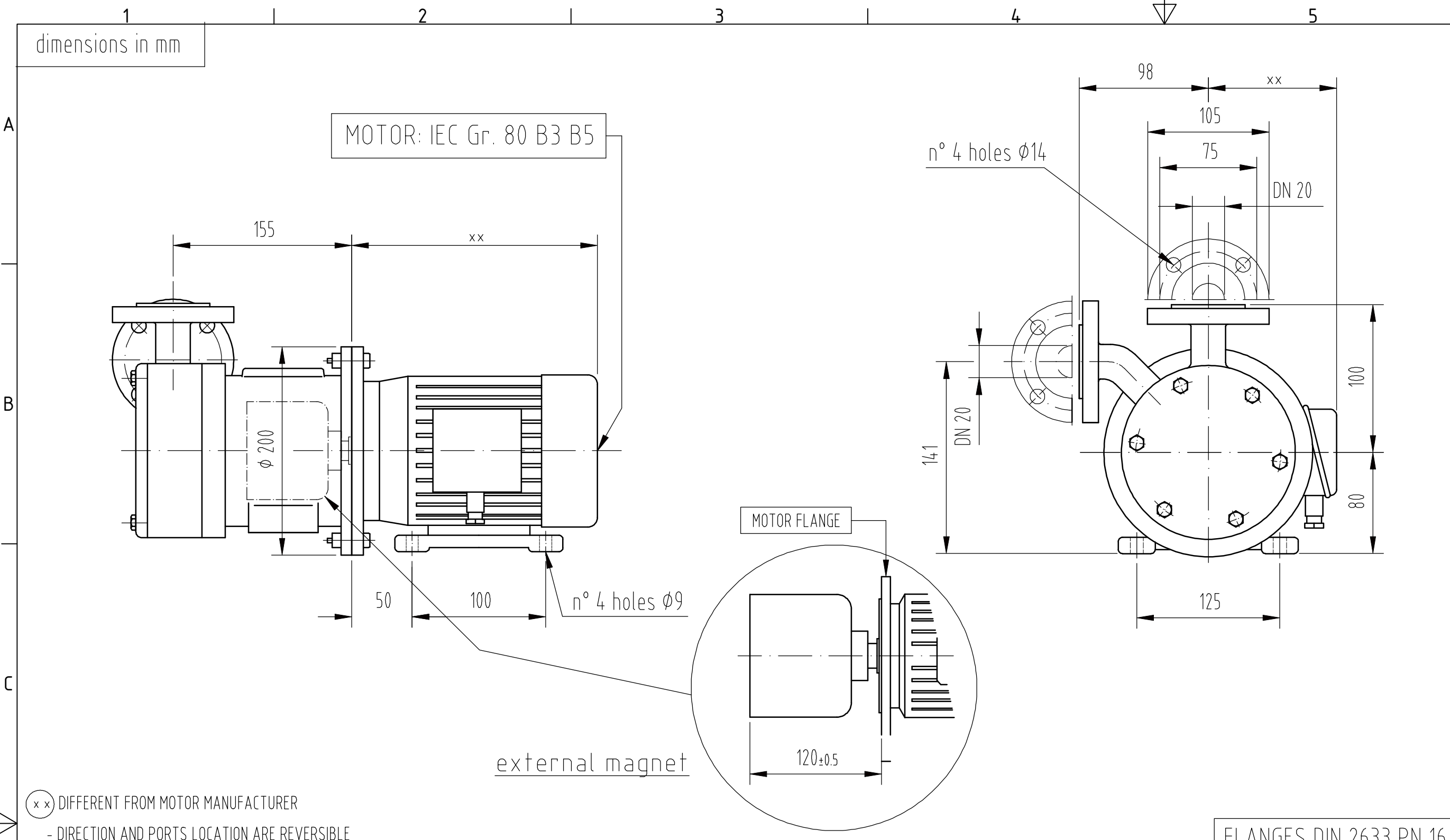

REF	DESCRIPTION	MATERIAL	CODE
10	Containment shell	SS 316L	
20	Ext. Magnet	CoSm/ Carbon Steel	
30	Int. Magnet	SS 316L/CoSm	
40	Impeller	SS 316L	
50	Set O-Rings (a+b+c) a + b = O-Ring 4300 (234) c = O-Ring 4362 (239)	Viton	
61	Thrust Bearings	Pcarbon	
62	Rear Ring	SS316L	
70	Shaft	SS316L	
75	Sleeve Bearings Bearings (d+e) Bearing (f)	Pcarbon SS316	
78	Bracket (200-130-19)	CAST IRON	
79	Rub Ring	Bronze	
84	End Cover	SS 316L	
85	Pump Casing	SS 316L	
88	Rear Wet End (10+30+40+50+61+62+70+75)	/	

(xx) DIFFERENT FROM MOTOR MANUFACTURER  
- DIRECTION AND PORTS LOCATION ARE REVERSIBLE

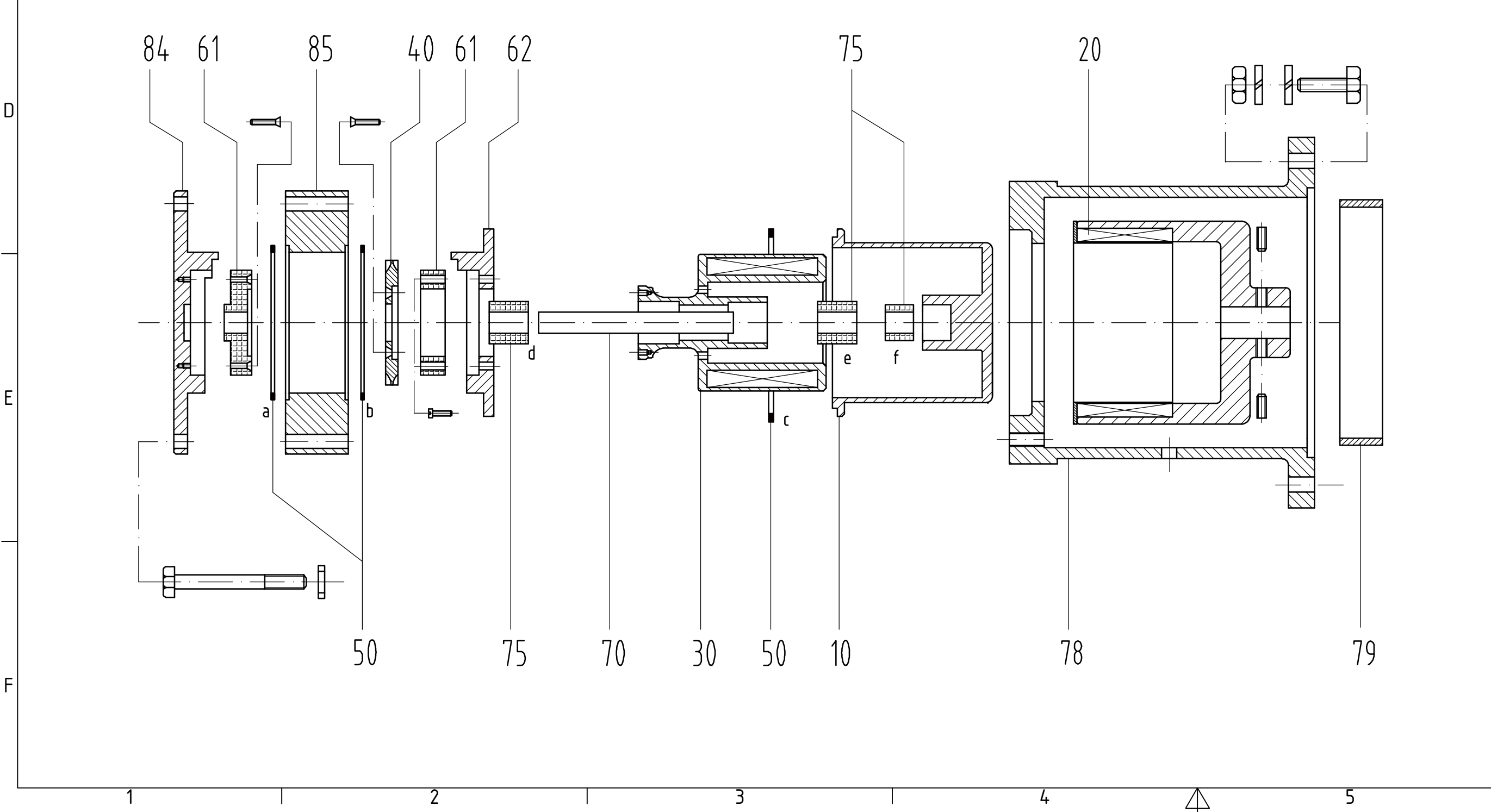

Alle Angaben unverbindlich, technische Änderungen vorbehalten! Technical data not binding and subject to change!  
Copyright MARCH PUMPEN GmbH & Co.KG 2019

	MARCH PUMPEN GmbH & Co.KG Rätthausstraße 2 D-35394 Gießen info@march-pumpen.com www.march-pumpen.com			Allgemeintoleranzen nach DIN ISO 2768-m Alle Kanten gratfrei	
	Gezeichnet 05.04.2019	Datum 05.04.2019		Name Lach	<b>MAG DRIVE TURBINE PUMPS</b> <b>MTA 37 SSF IEC80</b>
Status			Änderungen		Datum
Name			Datum		Name
DPCA-0037-SSF-IEC80					1 A2



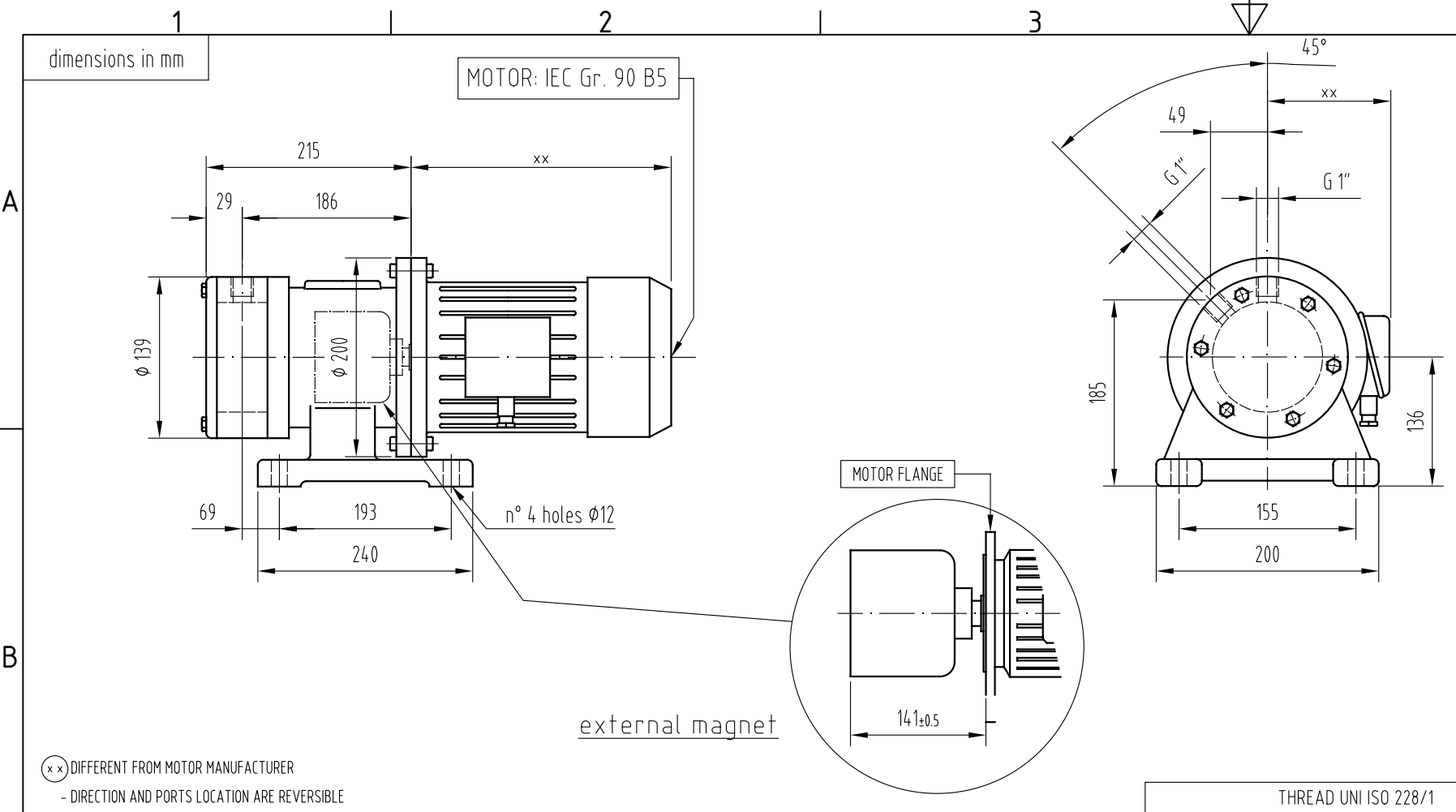

REF	DESCRIPTION	MATERIAL	CODE
10	Containment shell	SS 316L	
20	Ext. Magnet	CoSm/ Carbon Steel	
30	Int. Magnet	SS 316L/CoSm	
40	Impeller	SS 316L	
50	Set O-Rings (a+b+c) a + b = O-Ring 4337 (237) c = O-Ring 4400 (242)	Viton	
61	Thrust Bearings	Pcarbon	
62	Rear Ring	SS316L	
70	Shaft	SIC	
75	Sleeve Bearings Bearings (d+e) Bearing (f)	SIC SS316	
78	Bracket (200-130-24)	Cast Iron	
79	Rub Ring	Bronze	
84	End Cover	SS 316L	
85	Pump Casing	SS 316L	
88	Rear Wet End (10+30+40+50+61+62+70+75)	/	

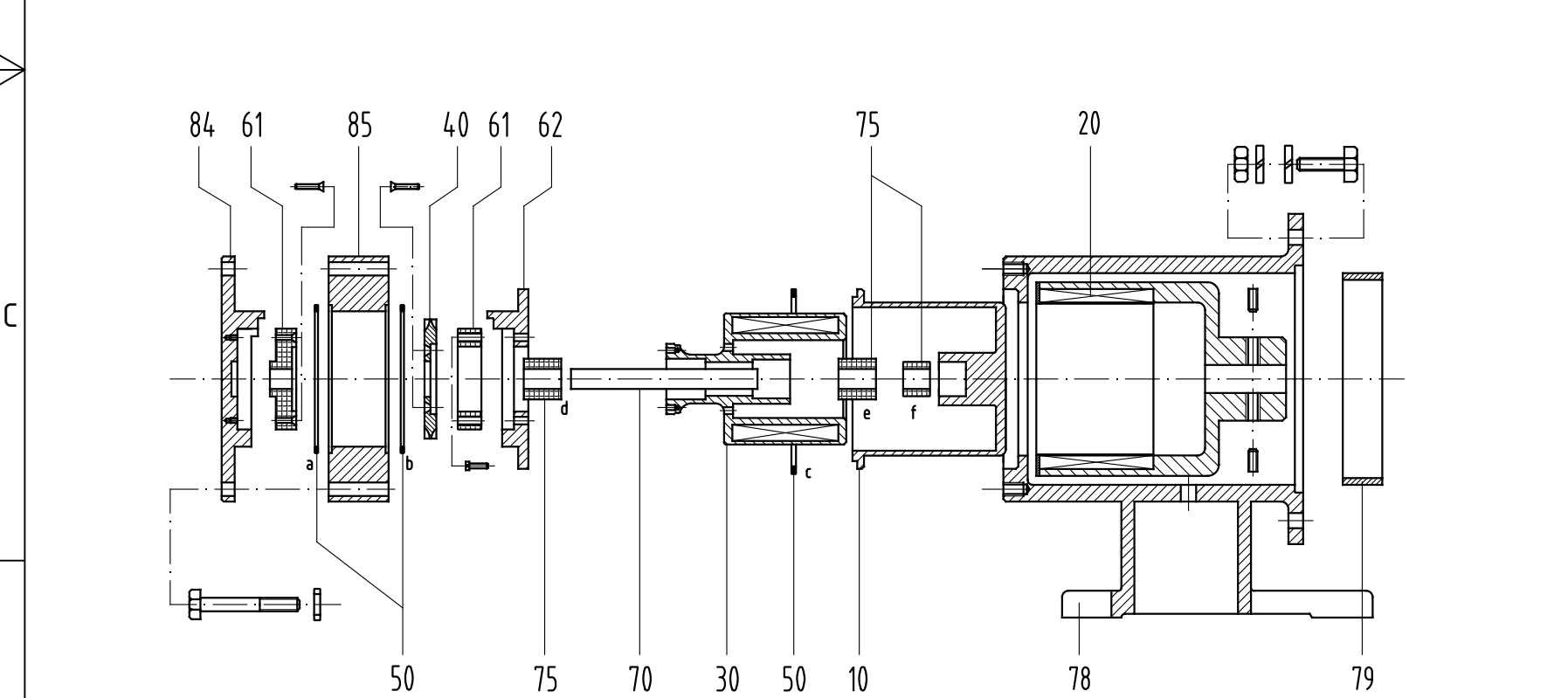

<p><b>MARCH PUMPEN GmbH &amp; Co.KG</b>  Rathenaustraße 2  D-35394 Gießen  www.march-pumpen.com  info@march-pumpen.com</p>	Baureihe / Series:	MTA
	Typ / Type:	MTA 49 SSR
	Motor:	IEC 90 B5

dimensions in mm

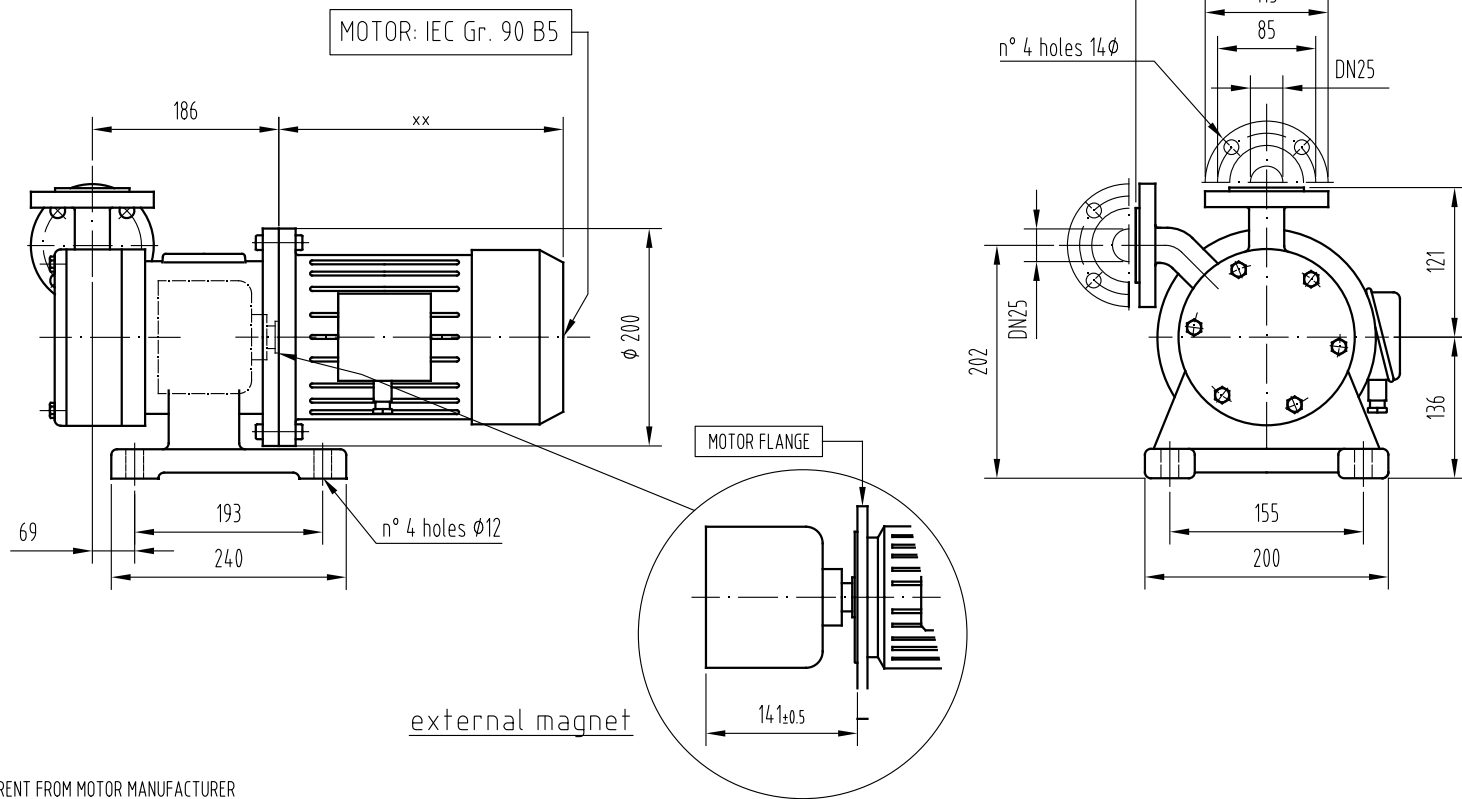

xx DIFFERENT FROM MOTOR MANUFACTURER  
- DIRECTION AND PORTS LOCATION ARE REVERSIBLE

FLANGES DIN 2633 PN 16

REF	DESCRIPTION	MATERIAL	CODE
10	Containment shell		
20	Ext. Magnet		
30	Int. Magnet		
40	Impeller		
50	Set O-Rings (a+b+c) a + b = O-Ring 4337 (237) c = O-Ring 4400 (242)		
61	Thrust Bearings		
62	Rear Ring		
70	Shaft		
75	Sleeve Bearings Bearings (d+e) Bearing (f)		
78	Bracket (200-130-24)		
79	Rub Ring		
84	End Cover		
85	Pump Casing		
88	Rear Wet End (10+30+40+50+61+62+70+75)		

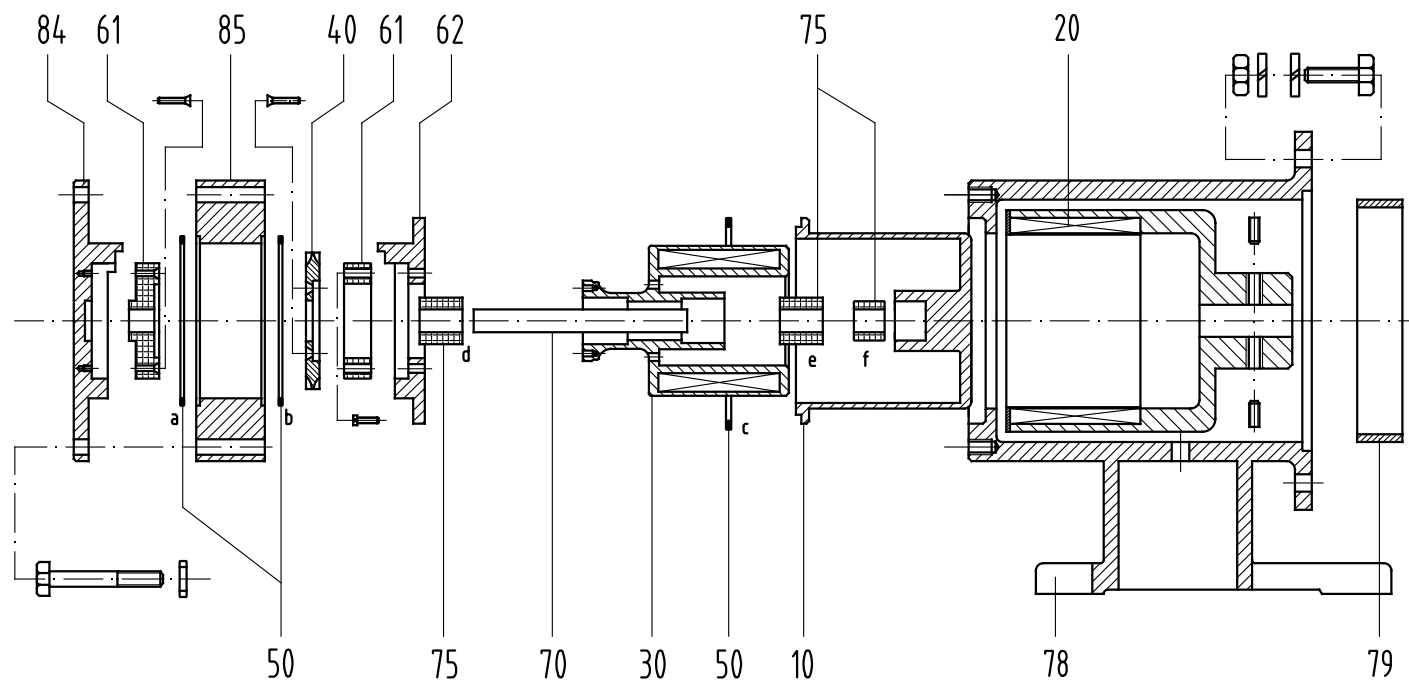

**MARCH PUMPEN GmbH & Co.KG**  
 Rathenastraße 2  
 D-35394 Gießen  
 www.march-pumpen.com  
 info@march-pumpen.com

Baureihe / Series:	MTA
Typ / Type:	MTA 49 SSF
Motor:	IEC 90 B5

1 dimensions in mm

A

B

C

D

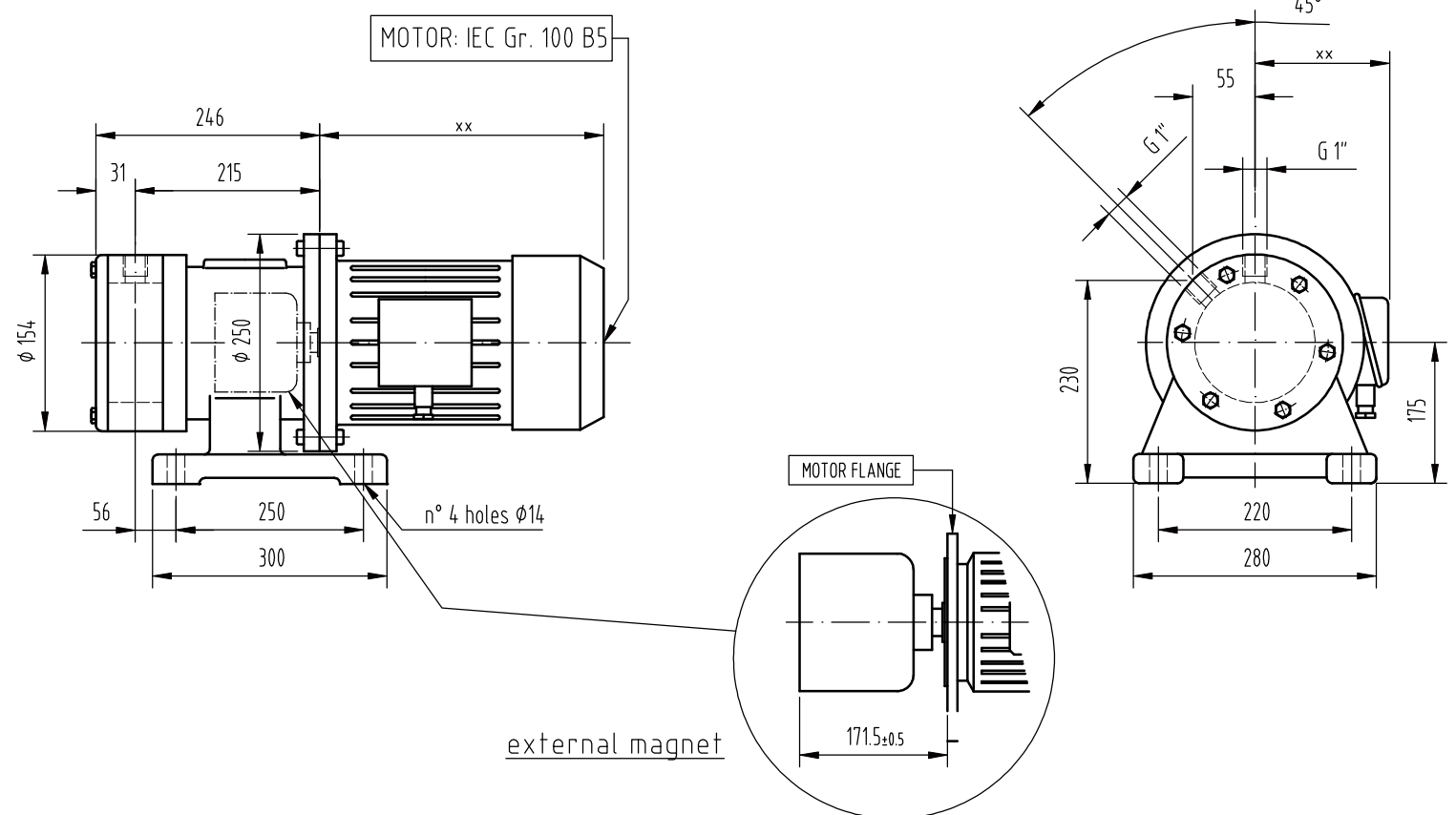

(x) DIFFERENT FROM MOTOR MANUFACTURER  
- DIRECTION AND PORTS LOCATION ARE REVERSIBLE

THREAD UNI ISO 228/1

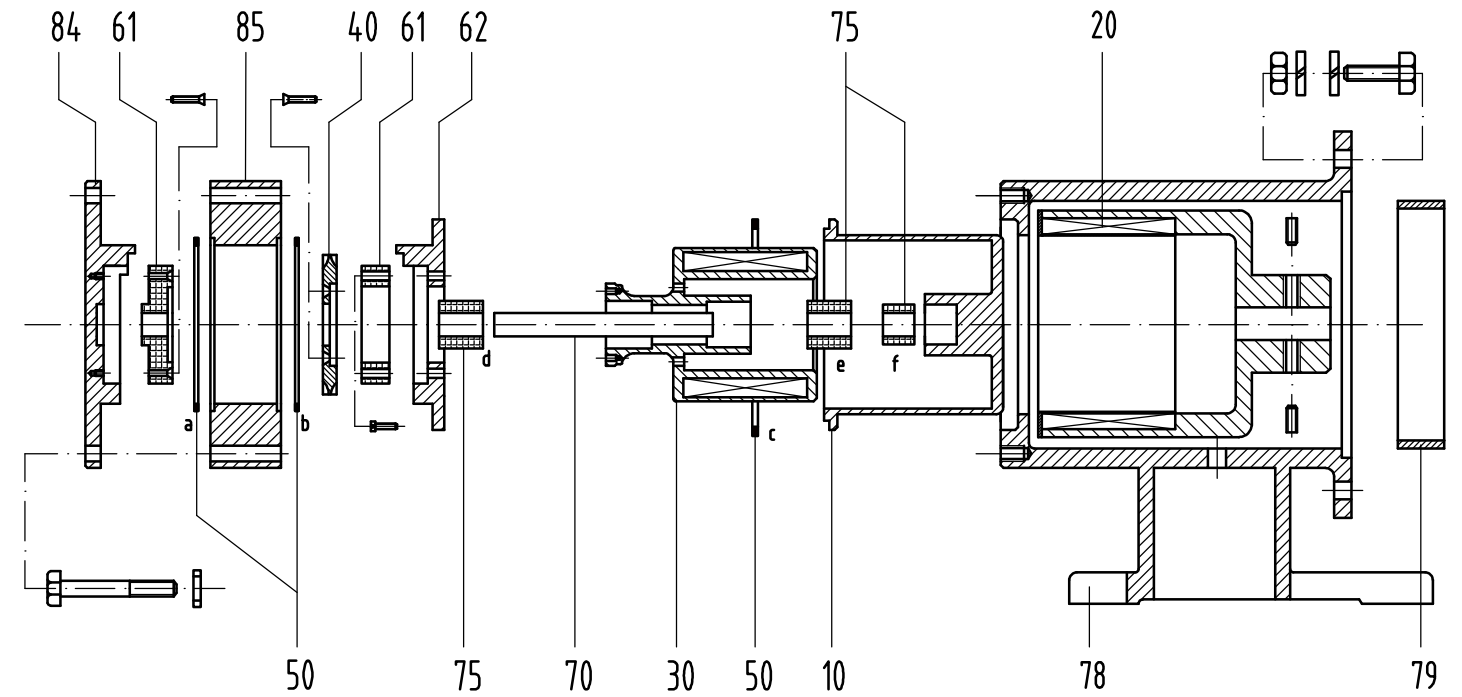

REF	DESCRIPTION	MATERIAL	CODE
10	Containment shell	SS 316L	
20	Ext. Magnet	CoSm/ Carbon Steel	
30	Int. Magnet	SS 316L/CoSm	
40	Impeller	SS 316L	
50	Set O-Rings (a+b+c) a + b = O-Ring 4375 (240) c = O-Ring 4437 (245)	Viton	
61	Thrust Bearings	Pcarbon	
62	Rear Ring	SS316L	
70	Shaft	SIC	
75	Sleeve Bearings Bearings (d+e) Bearing (f)	SIC SS316	
78	Bracket (250-180-28)	Cast Iron	
79	Rub Ring	Bronze	
84	End Cover	SS 316L	
85	Pump Casing	SS 316L	
88	Rear Wet End (10+30+40+50+61+62+70+75)	/	



**MARCH PUMPEN GmbH & Co.KG**  
 Rathenastraße 2  
 D-35394 Gießen  
 www.march-pumpen.com  
 info@march-pumpen.com

Baureihe / Series:	MTA
Typ / Type:	MTA 78 SSR
Motor:	IEC 100 B5

1 2 3 4 5 6

dimensions in mm

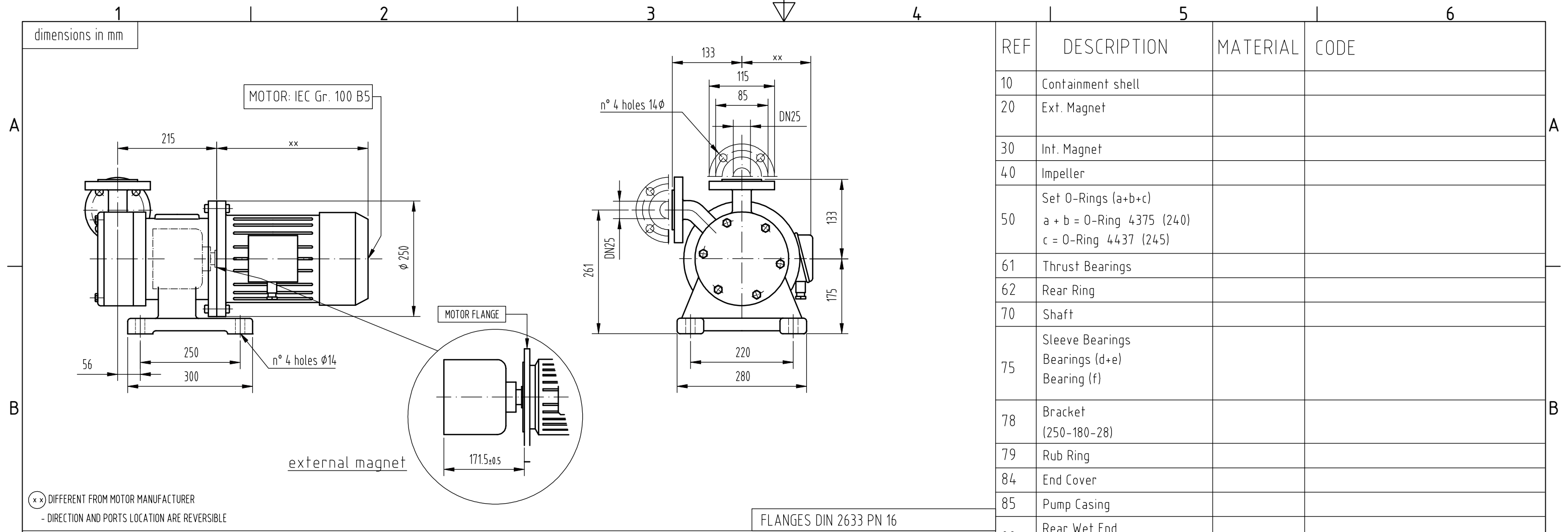

(x) DIFFERENT FROM MOTOR MANUFACTURER  
- DIRECTION AND PORTS LOCATION ARE REVERSIBLE

FLANGES DIN 2633 PN 16

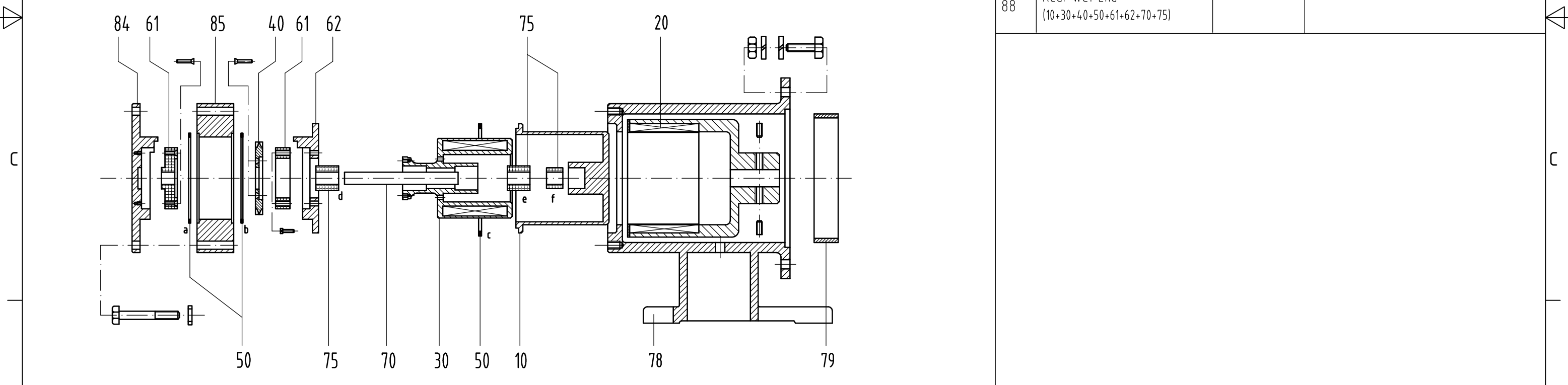

REF	DESCRIPTION	MATERIAL	CODE
10	Containment shell		
20	Ext. Magnet		
30	Int. Magnet		
40	Impeller		
50	Set O-Rings (a+b+c) a + b = O-Ring 4375 (240) c = O-Ring 4437 (245)		
61	Thrust Bearings		
62	Rear Ring		
70	Shaft		
75	Sleeve Bearings Bearings (d+e) Bearing (f)		
78	Bracket (250-180-28)		
79	Rub Ring		
84	End Cover		
85	Pump Casing		
88	Rear Wet End (10+30+40+50+61+62+70+75)		



**MARCH PUMPEN GmbH & Co.KG**  
 Rathenastraße 2  
 D-35394 Gießen  
 www.march-pumpen.com  
 info@march-pumpen.com

Baureihe / Series:	MTA
Typ / Type:	MTA 78 SSF
Motor:	IEC 100/112 B5

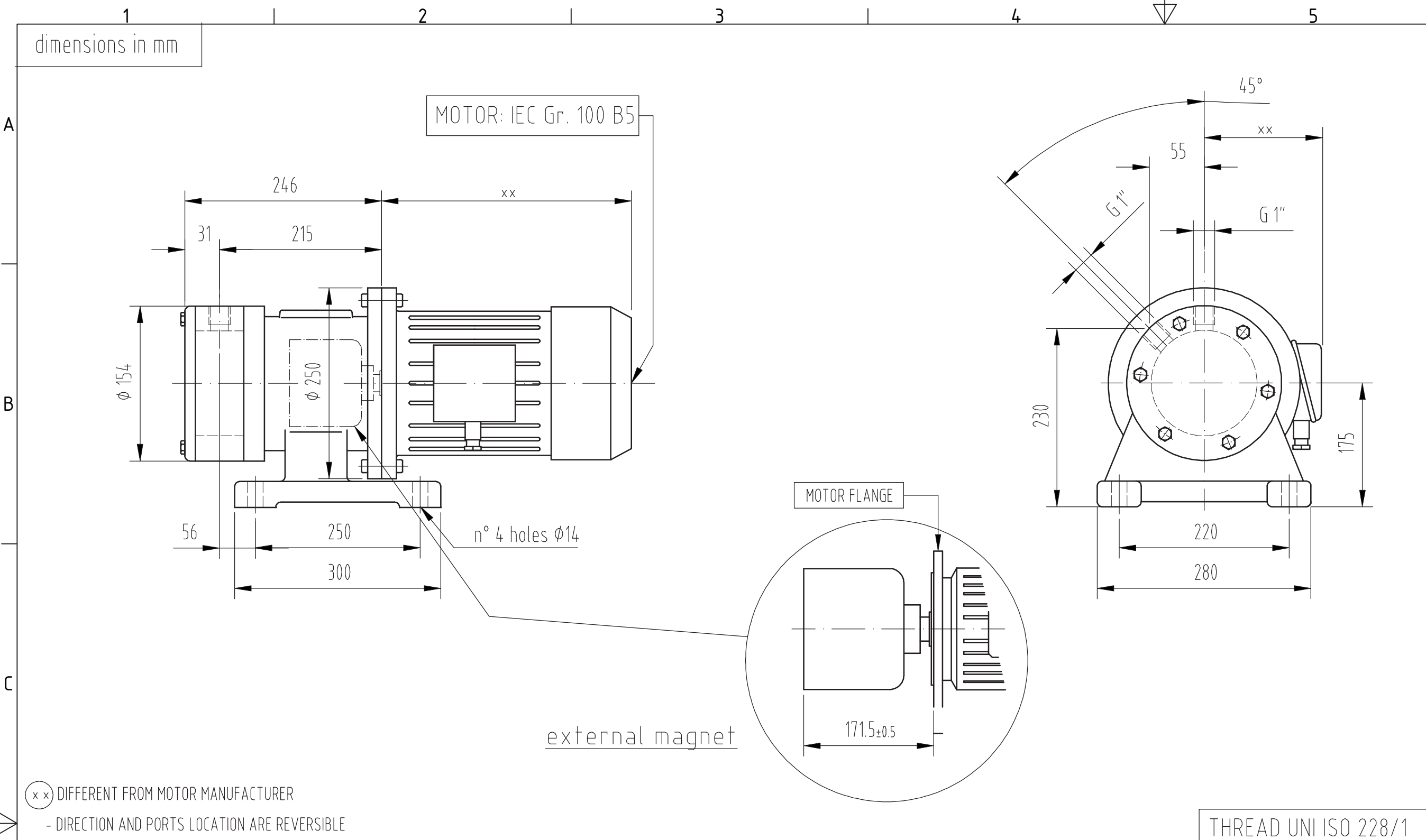

REF	DESCRIPTION	MATERIAL	CODE
10	Containment shell	SS 316L	
20	Ext. Magnet	CoSm/ Carbon Steel	
30	Int. Magnet	SS 316L/CoSm	
40	Impeller	SS 316L	
50	Set O-Rings (a+b+c) a + b = O-Ring 4375 (240) c = O-Ring 4437 (245)	Viton	
61	Thrust Bearings	Pcarbon	
62	Rear Ring	SS316L	
70	Shaft	SS316L	
75	Sleeve Bearings Bearings (d+e) Bearing (f)	Pcarbon SS316	
78	Bracket (250-180-28)	Cast Iron	
79	Rub Ring	Bronze	
84	End Cover	SS 316L	
85	Pump Casing	SS 316L	
88	Rear Wet End (10+30+40+50+61+62+70+75)	/	

⊗ DIFFERENT FROM MOTOR MANUFACTURER  
- DIRECTION AND PORTS LOCATION ARE REVERSIBLE

THREAD UNI ISO 228/1

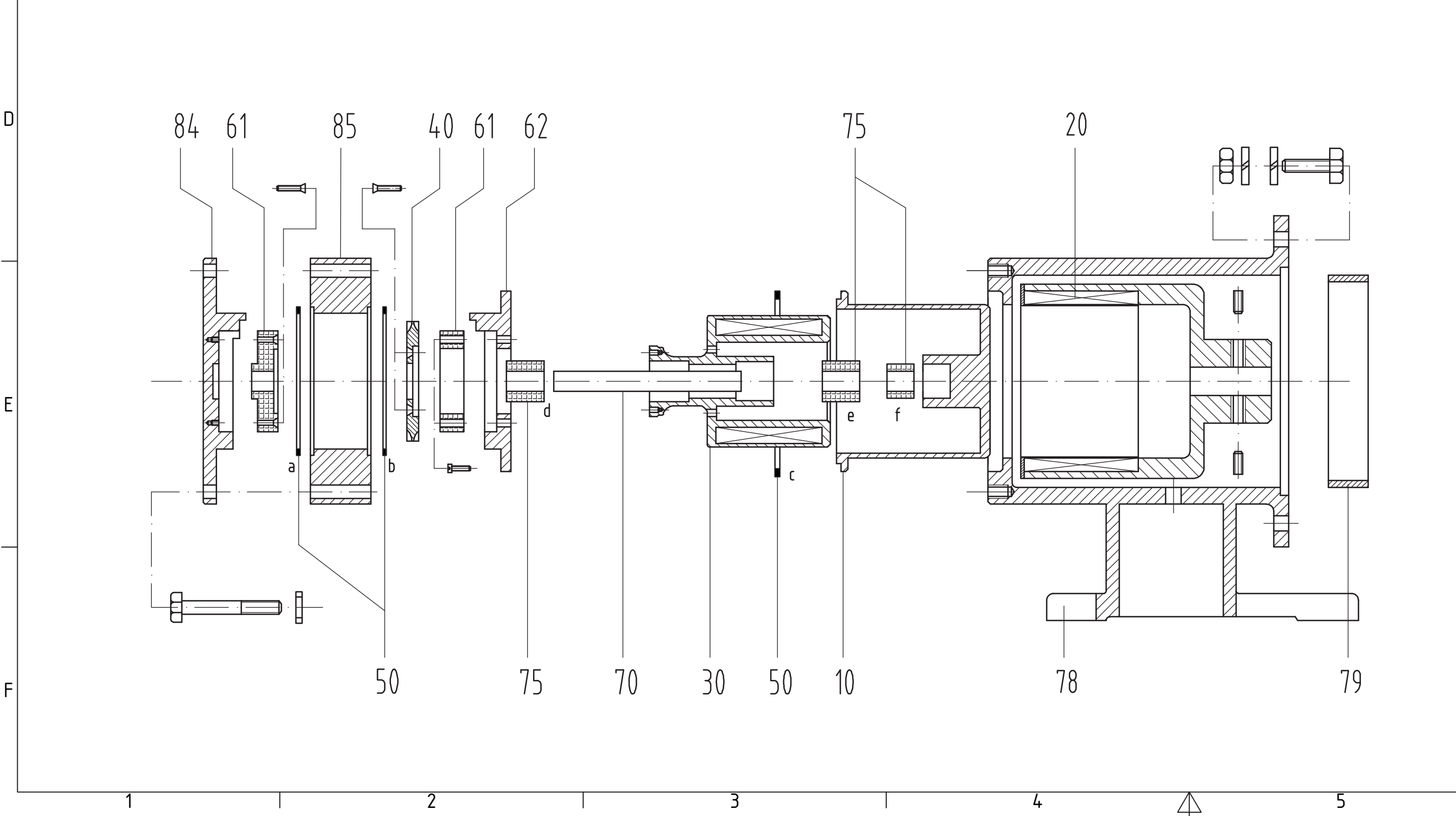

Alle Angaben unverbindlich, technische Änderungen vorbehalten! Technical data not binding and subject to change!  
Copyright MARCH PUMPEN GmbH & Co.KG 2019

	MARCH PUMPEN GmbH & Co.KG Rätthausstraße 2 D-35394 Gießen info@march-pumpen.com www.march-pumpen.com		Allgemeintoleranzen nach DIN ISO 2768-m Alle Kanten gratfrei	
			Datum: 02.07.2019 Name: Lach	Series MTA MTA 1011 SSR IEC100
DPCA-1011-SSR-IEC100			1 A2	
Status	Änderungen	Datum	Name	



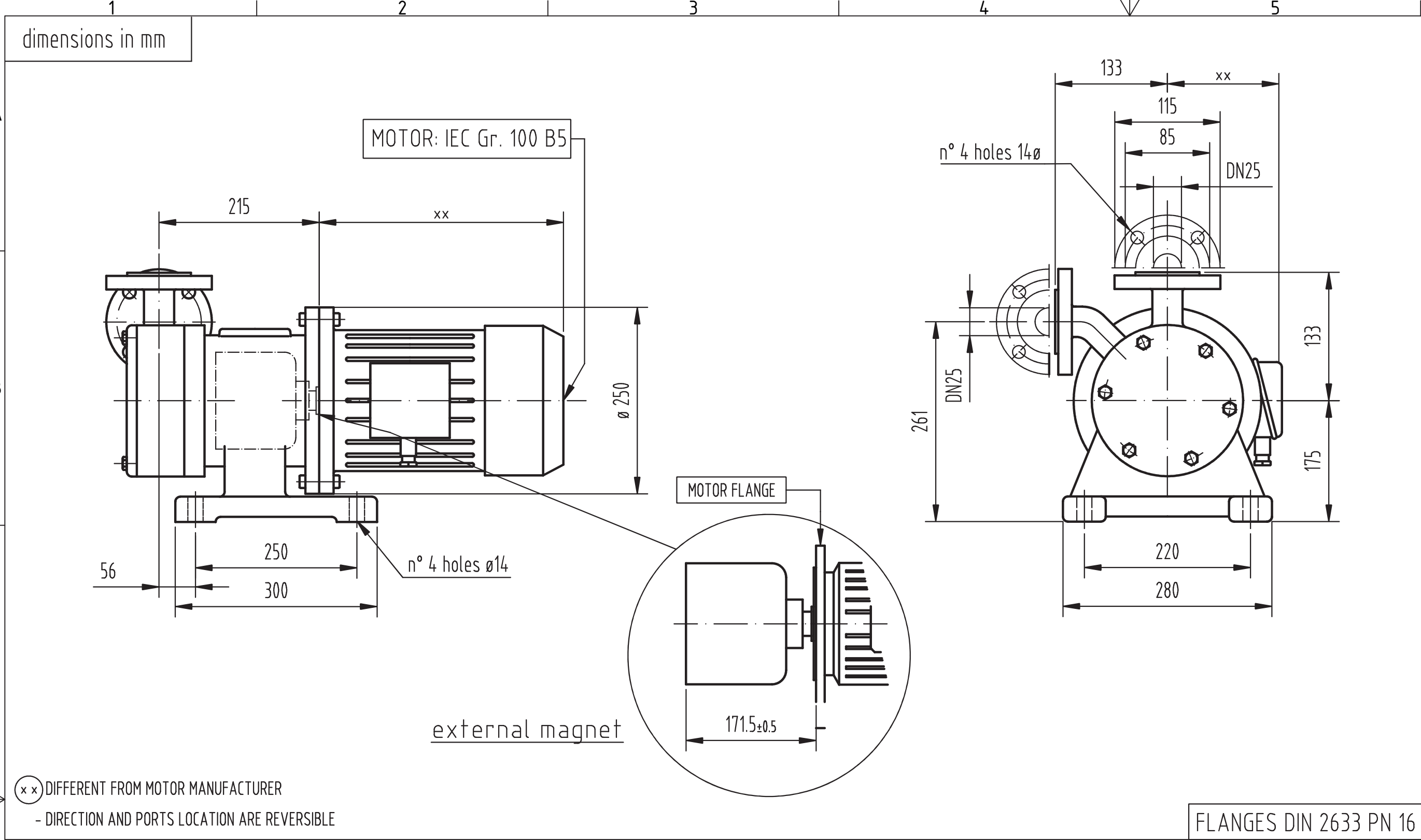

REF	DESCRIPTION	MATERIAL	CODE
10	Containment shell	SS 316L	
20	Ext. Magnet	CoSm/ Carbon Steel	
30	Int. Magnet	SS 316L/CoSm	
40	Impeller	SS 316L	
50	Set O-Rings (a+b+c) a + b = O-Ring 4375 (240) c = O-Ring 4437 (245)	Viton	
61	Thrust Bearings	Pcarbon	
62	Rear Ring	SS316L	
70	Shaft	SIC	
75	Sleeve Bearings Bearings (d+e) Bearing (f)	SIC SS316	
78	Bracket (250-180-28)	Cast Iron	
79	Rub Ring	Bronze	
84	End Cover	SS 316L	
85	Pump Casing	SS 316L	
88	Rear Wet End (10+30+40+50+61+62+70+75)	/	

xx DIFFERENT FROM MOTOR MANUFACTURER  
- DIRECTION AND PORTS LOCATION ARE REVERSIBLE

FLANGES DIN 2633 PN 16

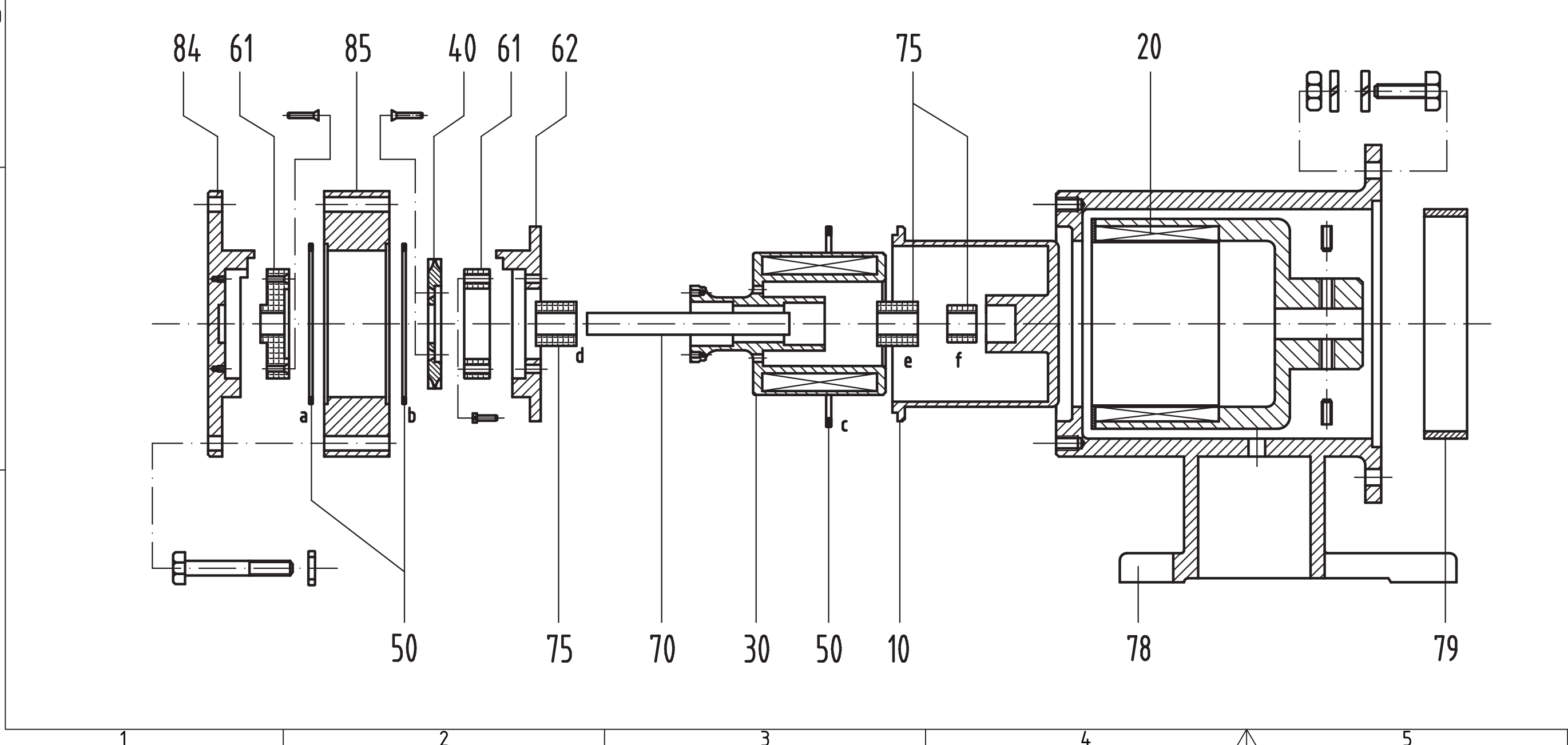

Alle Angaben unverbindlich, technische Änderungen vorbehalten! Technical data not binding and subject to change!  
Copyright MARCH PUMPEN GmbH & Co.KG 2019

	MARCH PUMPEN GmbH & Co.KG Rätthausstraße 2 D-35394 Gießen info@march-pumpen.com www.march-pumpen.com			Allgemeintoleranzen nach DIN ISO 2768-m Alle Kanten gratfrei	
	Gezeichnet Kontrolliert Norm	Datum 02.07.2019		Name Lach	Series MTA MTA 1011 SSF IEC100/112
DPCA-1011-SSF-100/112			1 A2		
Status	Änderungen	Datum	Name		

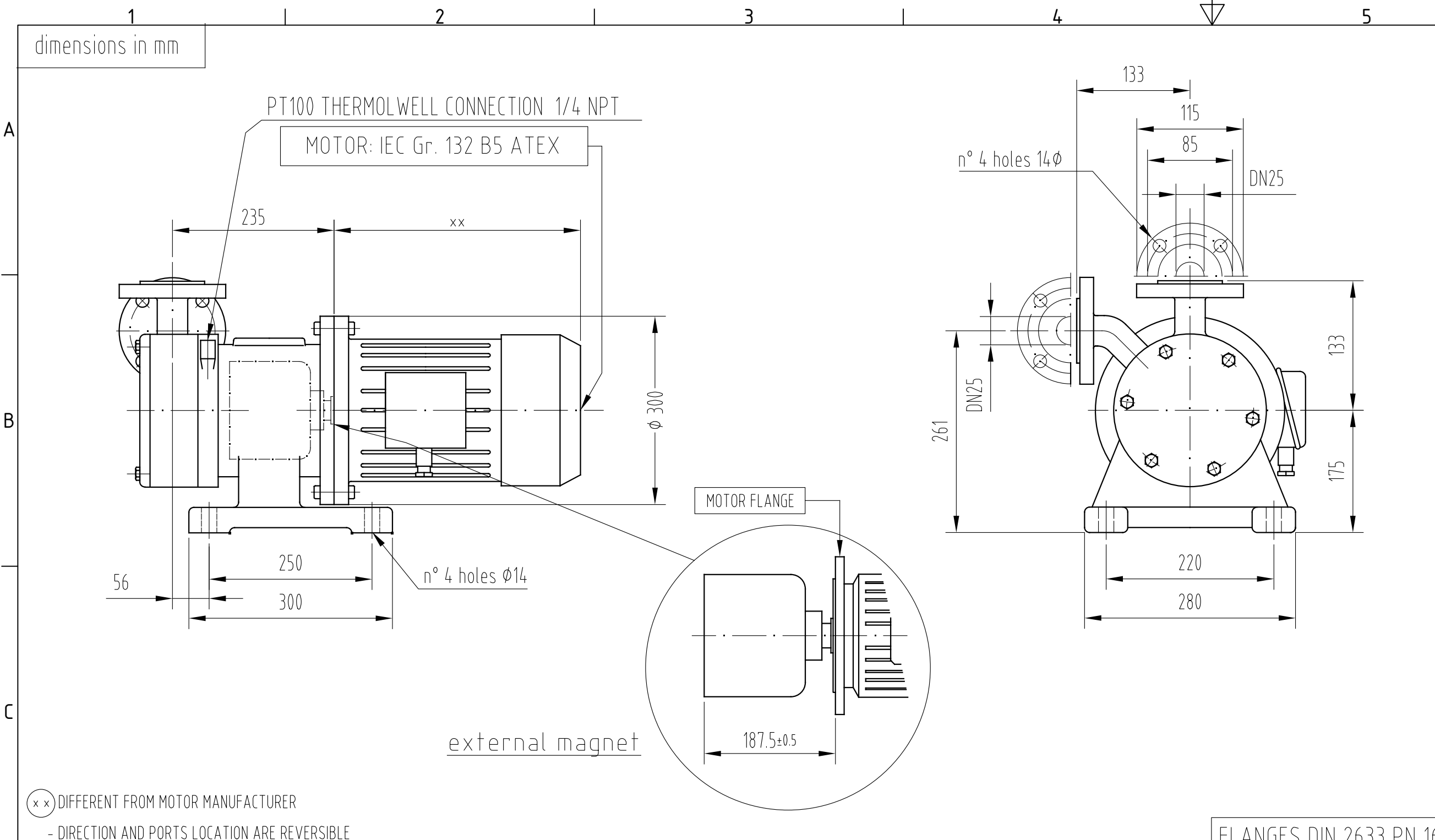

⊗ ⊗ DIFFERENT FROM MOTOR MANUFACTURER  
 - DIRECTION AND PORTS LOCATION ARE REVERSIBLE

REF	DESCRIPTION	MATERIAL	CODE
10	Containment shell	SS 316L	
20	Ext. Magnet	CoSm/ Carbon Steel	
30	Int. Magnet	SS 316L/CoSm	
40	Impeller	SS 316L	
50	Set O-Rings (a+b+c) a + b = O-Ring 4387 (241) c = O-Ring 4437 (245)	FEP	
61	Thrust Bearings	Pcarbon	
62	Rear Ring	SS316L	
70	Shaft	SIC	
75	Sleeve Bearings Bearings (d+e) Bearing (f)	SIC SS316	
78	Bracket (300-250-38)	Cast Iron	
79	Rub Ring	Bronze	
84	End Cover	SS 316L	
85	Pump Casing	SS 316L	
88	Rear Wet End (10+30+40+50+61+62+70+75)	/	

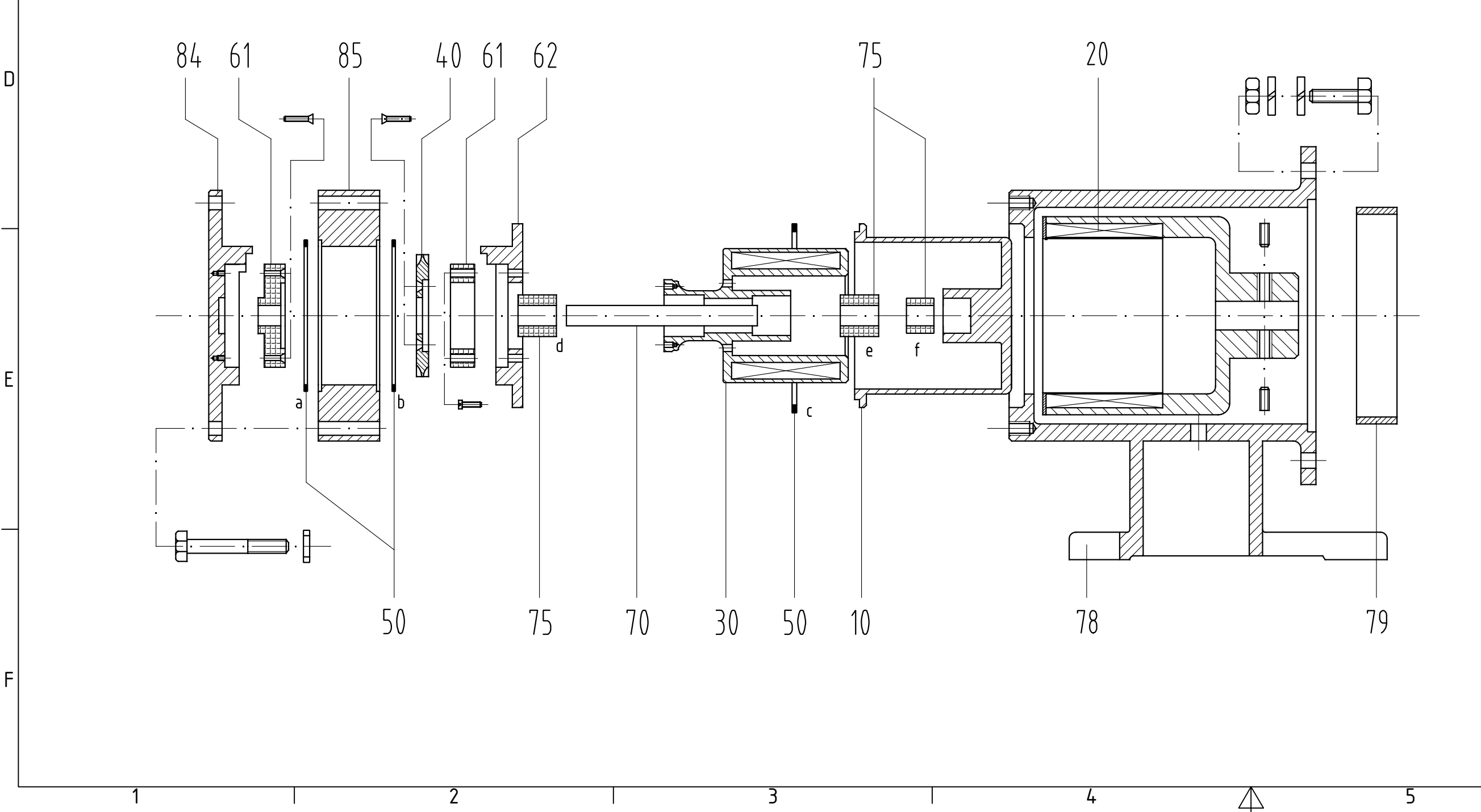

Alle Angaben unverbindlich, technische Änderungen vorbehalten! Technical data not binding and subject to change!  
 Copyright MARCH PUMPEN GmbH & Co.KG 2019

	MARCH PUMPEN GmbH & Co.KG Rätthausstraße 2 D-35394 Gießen info@march-pumpen.com www.march-pumpen.com			Allgemeintoleranzen nach DIN ISO 2768-m Alle Kanten gratfrei	
	Gezeichnet Kontrolliert Norm	Datum 05.04.2019		Name Lach	<b>MAG DRIVE TURBINE PUMPS</b> <b>MTA 1011 SSF IEC132</b>
			<b>DPCA-1011-SSF-IEC132</b>		<b>1</b> A2
Status	Änderungen	Datum	Name		

all dimensions in mm.

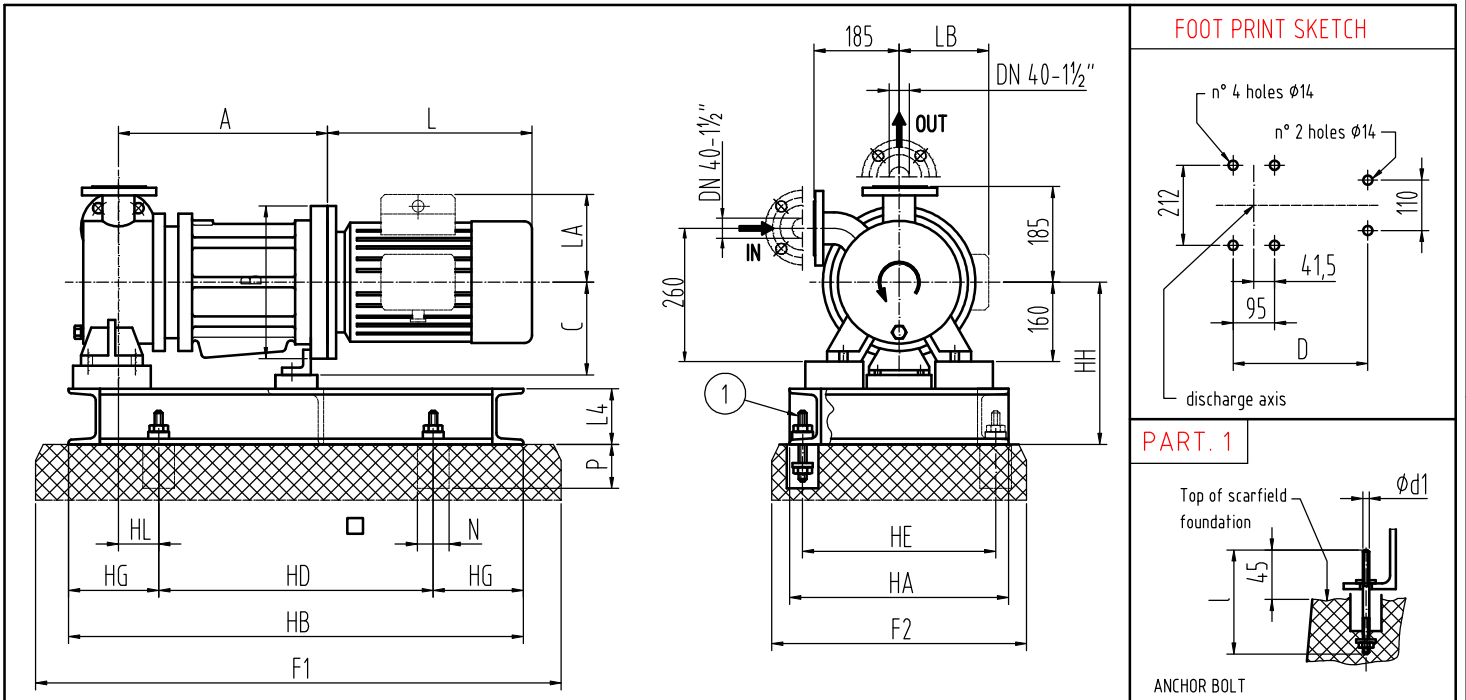

PUMP						FLANGES DIN 2634 - PN 25		FLANGES ANSI B 16.5 - 300 Lb RF	
MOTOR SIZE	A	B (φ)	C	D	WEIGHT (kg) (without motor)	SUCTION - DISCHARGE		SUCTION - DISCHARGE	
132	292	300	180	280	85				
160/180	322	350							
256C	12.67	11.03	7.08	11.02					

NEMA motor dimensions are in inches

MOTOR	OUTPUT MAX. (kW)		SHAFT Ød	H	L	LA	LB	WEIGHT (kg)	BASEPLATE										FOUNDATION				BOLTS Ød1 x l	
	2P	4P							BASEPLATE N°	HB	HD	HG	HL	HE	HA	L4	N° BOLTS	HH	WEIGHT (kg)	F1	F2	□		N
132 S	5,5	5,5	38	-					07	700	480	110	29	360	400	80	4	280	27	850	550	120	250	M16 x 270
	7,5																							
132 M	9,2	11,0	38	-					07	700	480	110	29	360	400	80	4	280	27	850	550	120	250	M16 x 270
	7,5																							
160 M	11,0	15,0	42	-					07	700	480	110	29	360	400	80	4	280	27	850	550	120	250	M16 x 270
	9,2																							
160 L	18,5	15,0	42	-					07	700	480	110	29	360	400	80	4	280	27	850	550	120	250	M16 x 270
180 M	22,0	18,5	48	-					07	700	480	110	29	360	400	80	4	280	27	850	550	120	250	M16 x 270
180 L	-	22,0	48	-					07	700	480	110	29	360	400	80	4	280	27	850	550	120	250	M16 x 270
256C	20HP	-	1.406	-					07	700	480	110	29	360	400	80	4	280	27	850	550	120	250	M16 x 270

<p>MARCH PUMPEN ...ADVANCED SOLUTIONS...</p>	<p><b>MARCH PUMPEN GmbH &amp; Co.KG</b> Rathenaustraße 2 D-35394 Gießen</p> <p>www.march-pumpen.com info@march-pumpen.com</p>	<p>Baureihe / Series: <b>MTA</b></p>
		<p>Typ / Type: <b>MTA 2020</b></p>
		<p>Motor: <b>2900 1/min</b></p>