

# MAGNETIC DRIVEN CENTRIFUGAL PUMP SERIES M

## M5

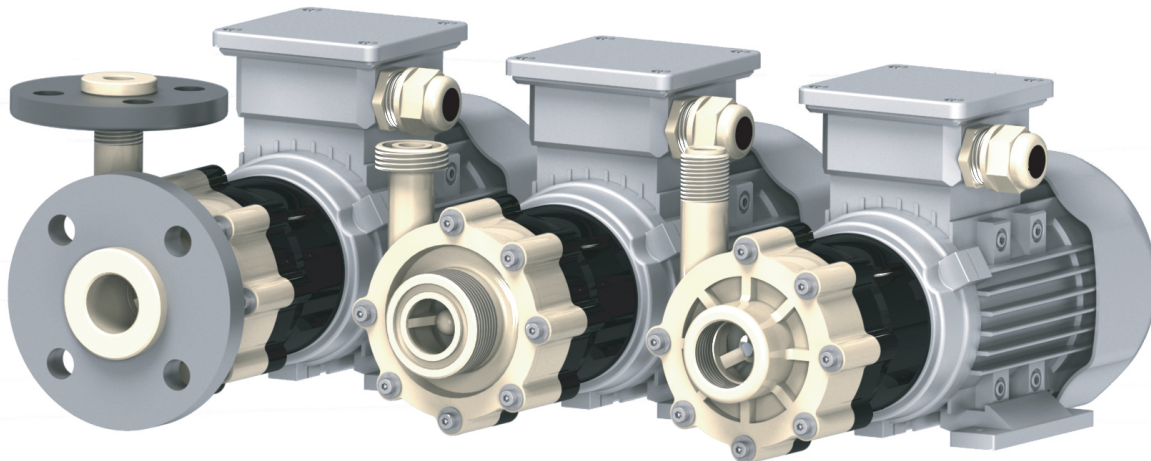

### MATERIAL CODE

M 5 PPR 400V 1" -1/2"/PVKPOP

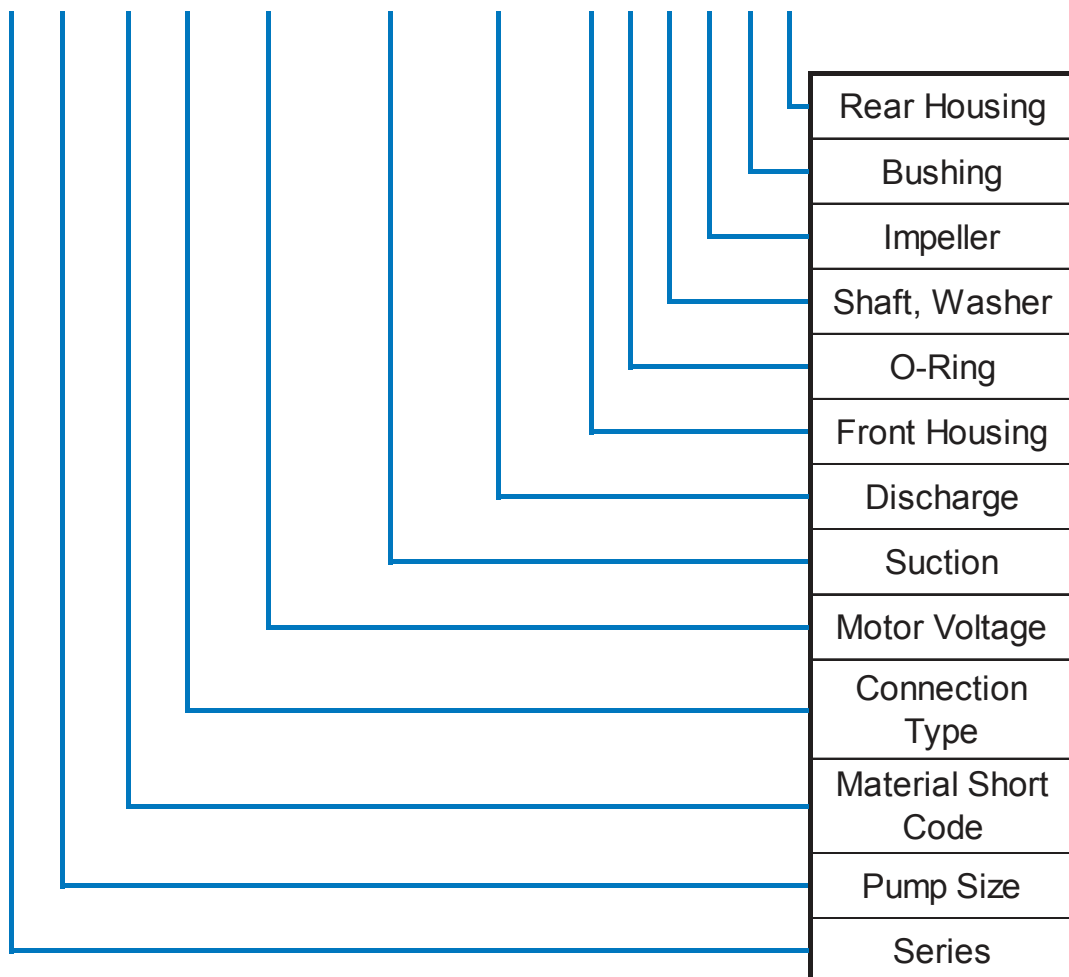

### DESIGN CHARACTERISTICS

- Leakfree
- Magnetic Driven
- Normal Suction
- Block Design

### CONNECTIONS

#### Suction

Threaded: BSP 1" female  
Einschraubteil: BSP 1 1/2" male  
Flange: DN 25

#### Discharge

Threaded: 1/2" MPT  
Einschraubteil: BSP 1" male  
Flange: DN 15

### MATERIALS

Housing: PP, PPS, PVDF  
O-Ring: FKM, FEP, EPDM

### TECHNICAL DATA

Flow Rate max.: 60 l/min  
Discharge Head max.: 6,4 mwc  
System Pressure max.: 3,5 bar  
Temperature max.: PP 70°C  
PPS 90°C  
PVDF 90°C  
Density max.: 1,5 kg/dm<sup>3</sup>  
Viscosity max.: 100 cP

### APPLICATIONS

- Chemical Industry
- Plant and Equipment Engineering
- Electroplating
- Filter Pumps
- Waste Water Treatment
- Acids, Bases and Solutions
- Hazardous Liquids

Material Short Code	Material
PP	PP
PV	PVDF
RY	PPS

Connection Type Short Code	Connection Type
R	Threaded
E	Union Bushing
F	Flange

Material Code											
Front Housing		O-Ring		Shaft, Washer		Impeller		Bushing		Rear Housing	
R	PPS	E	EPDM	K	Ceramic	R	PPS	O	w/o Bushing	R	PPS
P	PP	V	FKM			P	PP			P	PP
K	PVDF	F	FEP			K	PVDF			K	PVDF



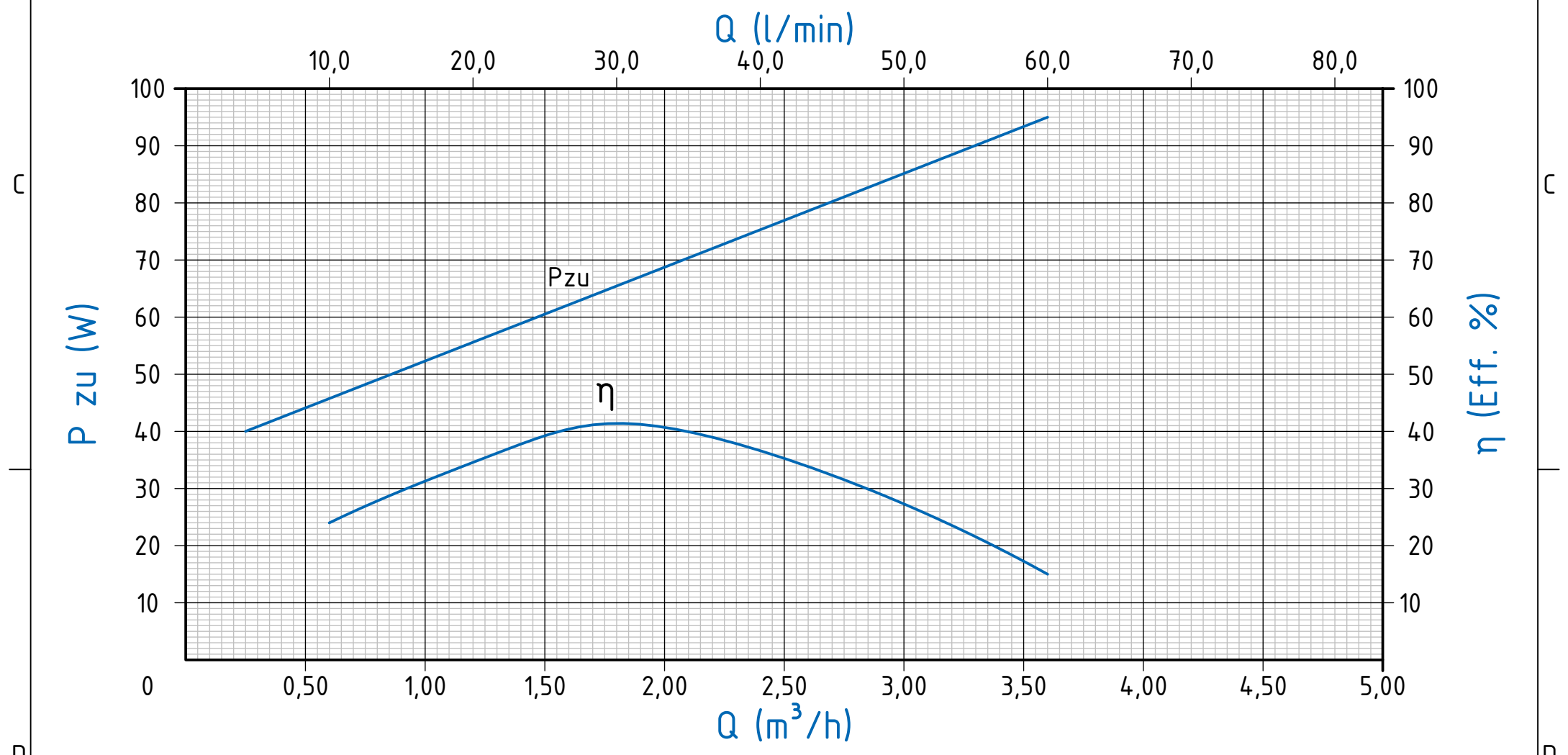
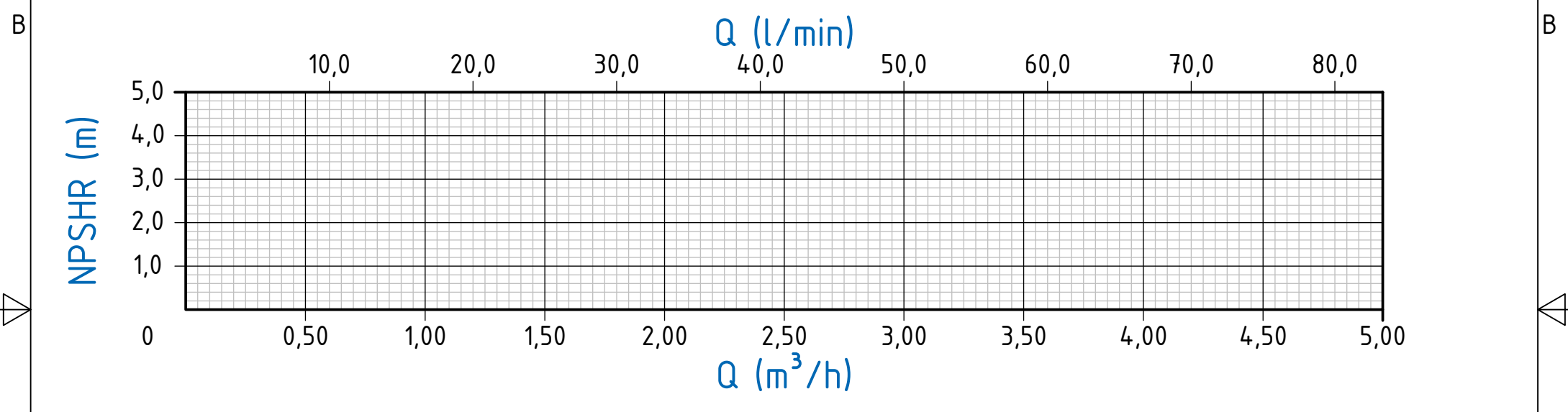
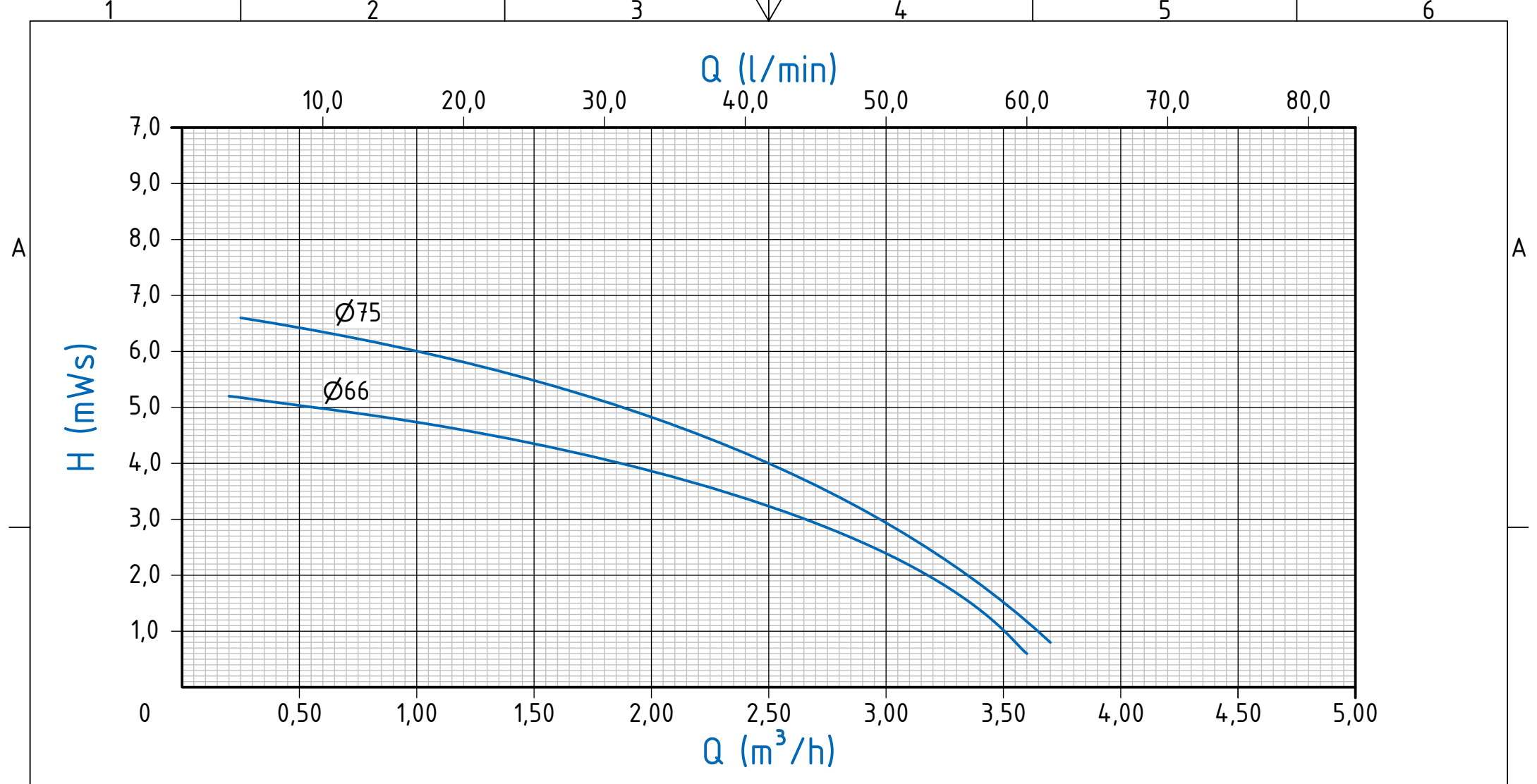

**MARCH PUMPEN GmbH & Co.KG**  
 Rathenastraße 2  
 D-35394 Gießen  
 www.march-pumpen.com  
 info@march-pumpen.com

Pumpe / Pump	Drehzahl / Speed	Lauftrad / Impeller	Dichte / S.G.	Baureihe / Series:
M5	2900	Ø 75 mm	max. 1,5 kg/dm³	M / Euroline
		Ø 66 mm		Typ / Type:
				M5
				Motor:
				230/400V-90W-2900RPM

# M4 / M5 / M5i PPF 230/400V

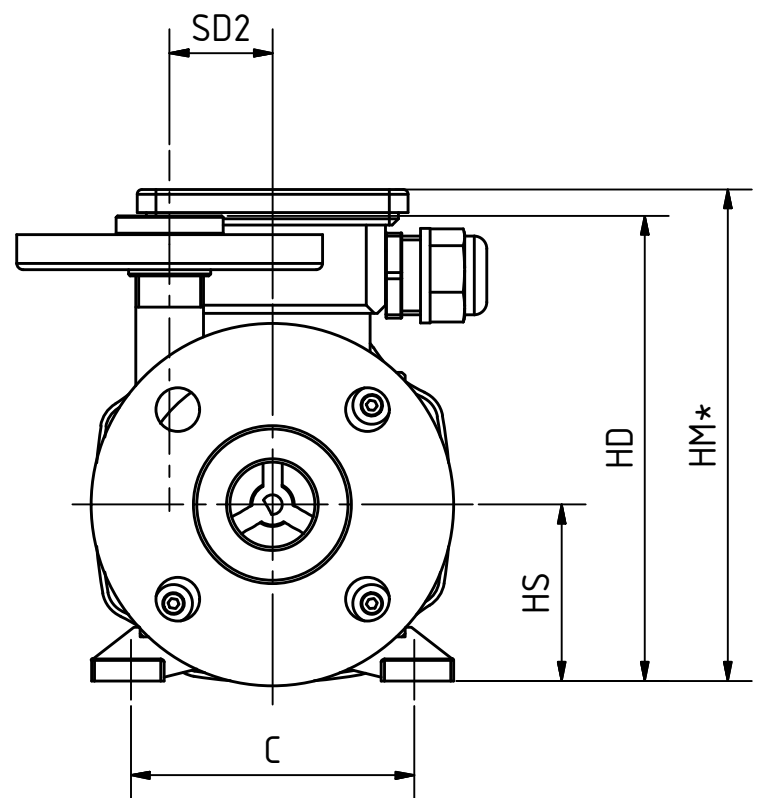
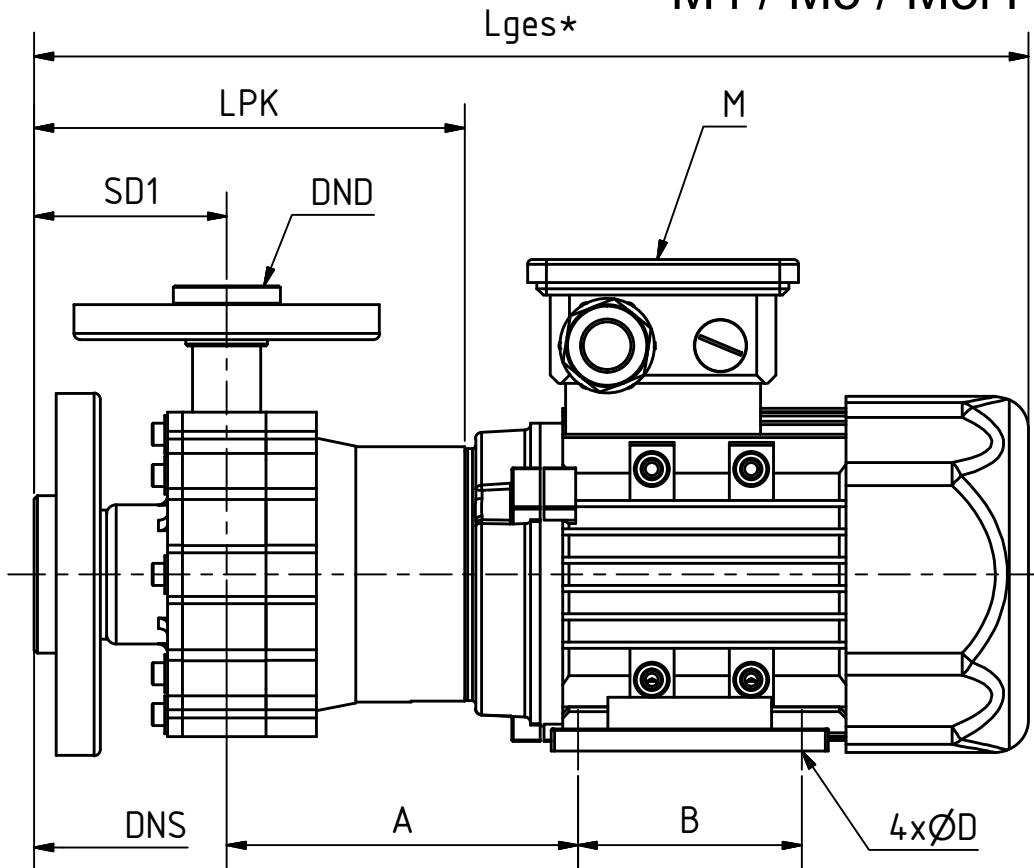

# M4 / M5 / M5i PPE 230/400V

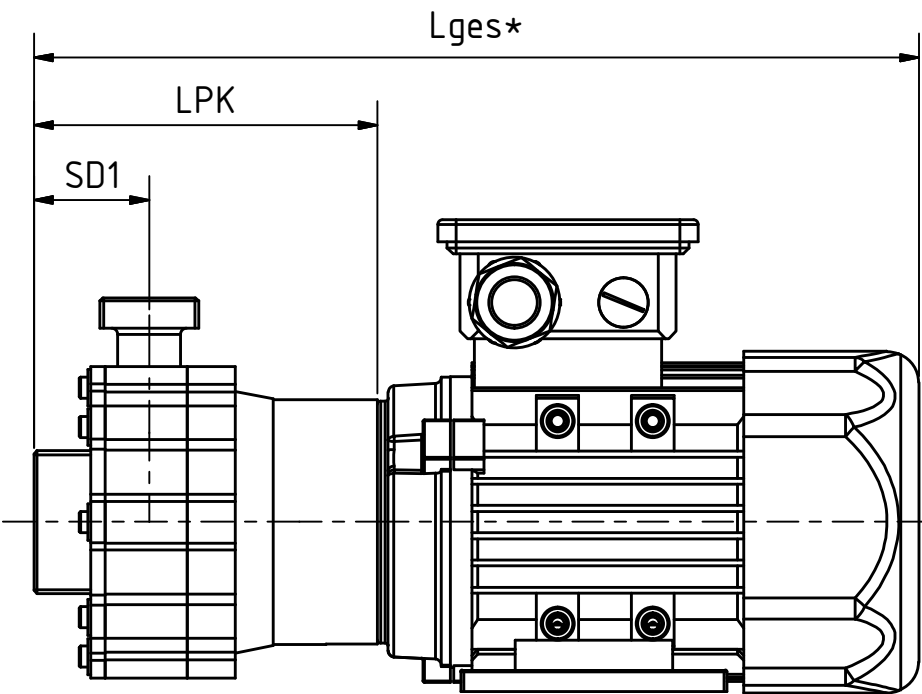

# M4 / M5 / M5i PPR 230/400V

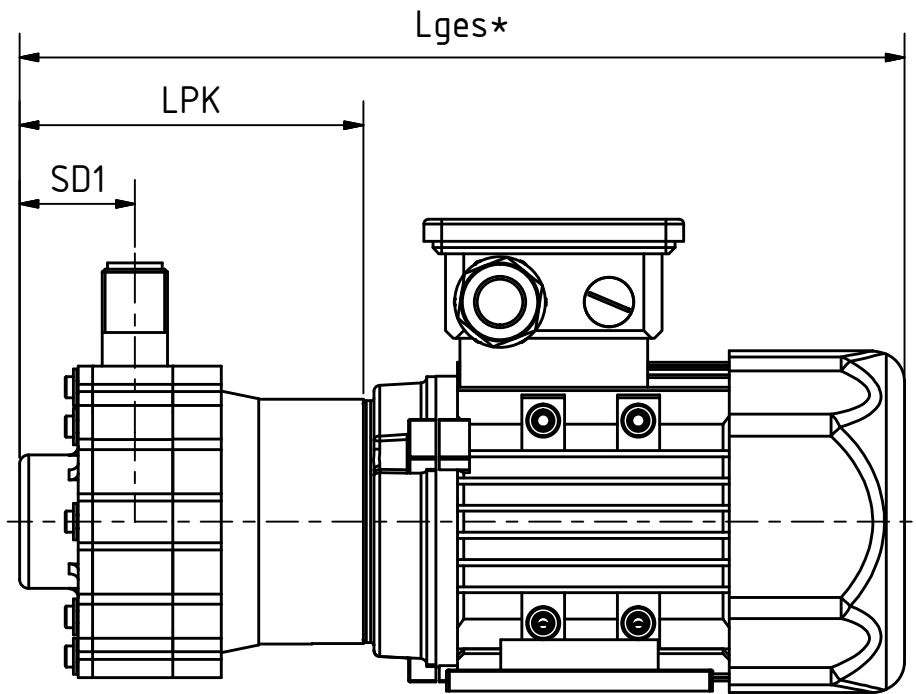

## Maßtabelle

Pumpentyp	M						DNS	DND	SD1	SD2
	Typ	U [V]	P [kW]	f [Hz]	n [min-1]					
M4/M5/M5i PPE 230V	IEC BG56 B34k	230	0,090	50	2900	-	1 1/2" BSP	1" BSP	38,10	
M4/M5/M5i PPE 400V		400								
M4/M5/M5i PPF 230V		230								
M4/M5/M5i PPF 400V		400								
M4/M5/M5i PPR 230V		230								
M4/M5/M5i PPR 400V		400								

Pumpentyp	Lges *	LPK	A	B	C	ØD	HS	HD	HM *
-	[mm]	[mm]	[mm]	[mm]	[mm]	[mm]	[mm]	[mm]	[mm]
M4/M5/M5i PPE 230V	273,60	113,60	111,50	71,00	90,00	6,00	56,00	130,15	152,10
M4/M5/M5i PPE 400V	292,60					5,80			156,00
M4/M5/M5i PPF 230V	296,60	136,60				6,00		147,60	152,10
M4/M5/M5i PPF 400V	315,60					5,80			156,00
M4/M5/M5i PPR 230V	273,60	113,60				6,00		141,60	152,10
M4/M5/M5i PPR 400V	292,60					5,80			156,00

\* Maß weicht bei anderen Motorfabrikaten ab

Alle Angaben unverbindlich, technische Änderungen vorbehalten! Technical data not binding and subject to change!  
Copyright MARCH PUMPEN GmbH 2015

MARCH PUMPEN GmbH Rathenastraße 2 D-35394 Gießen info@march-pumpen.com www.march-pumpen.com		Datum	Name	Produktzeichnung <i>Dimensional Drawing</i> Baureihe / Series M4 - M5 - M5i <b>PROD.ZCHG_M4_M5_M5i</b>	<b>1</b> A3
		Gezeichnet	09.03.2010		
Kontrolliert					
Norm					
Status	Änderungen	Datum	Name		

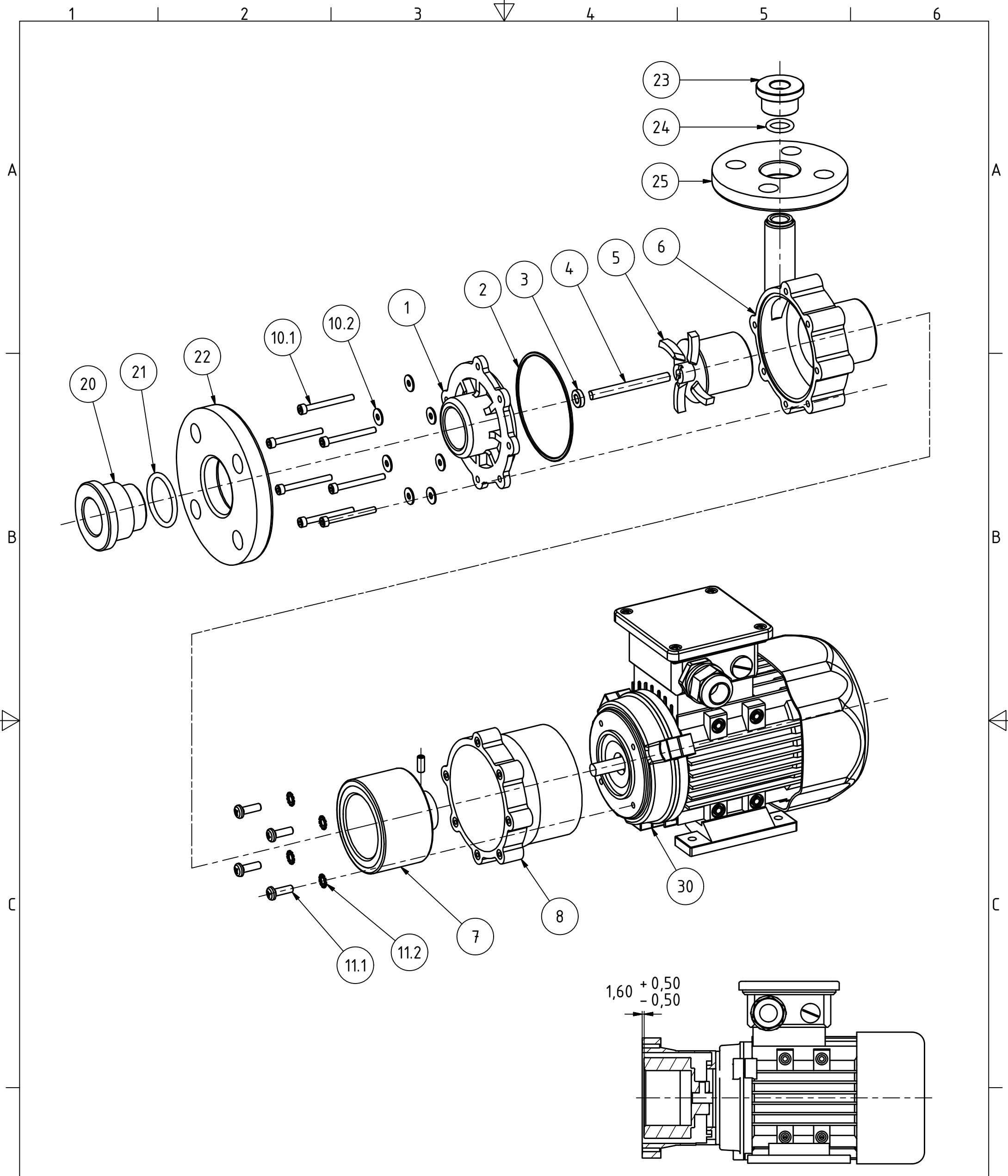

Alle Angaben unverbindlich, technische Änderungen vorbehalten! Technical data not binding and subject to change!  
 Copyright MARCH PUMPEN GmbH 2015

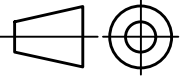
		MARCH PUMPEN GmbH Rathenastraße 2 D-35394 Gießen info@march-pumpen.com www.march-pumpen.com					
		Datum		Name		Explosionsdarstellung	
		Gezeichnet: 17.08.2015		P.Stachon		Explosion View	
		Kontrolliert:				Baureihe / Series M4 - M5 - M5i	
		Norm:				Explosion_M4_M5_M5i	
						1	
						A3	
Status	Änderungen	Datum	Name				

**STÜCKLISTE / PARTS LIST**

**SERIE / SERIES M4 / M5 / M5i**

POS	STÜCK	BESCHREIBUNG	MATERIAL	ARTIKELNR.
1	1	Vordergehäuse G 1" - IG	PP	MS1099-0002-1000
		Vordergehäuse 1" Schlauchanschluss	PP	MS0150-0150-1000
		Vordergehäuse 1" FPT	PP	MS0150-0032-1000
			PPS	MS0150-0073-1000
			PVDF	MS0150-0124-1000
			AISI 316 SS	MS0150-0111-0000
2	1	O-Ring	FKM	DT-OR-75x2-FKM80A
			FEP	DT-OR-75x2-FEP
			EPDM	DT-OR-75x2-EPDM
3	1	Axialscheibe, frontseitig	Keramik	MS0130-0028-1000
4	1	Welle	Keramik	MS0130-0024-1000
5	1	<b>Flügelrad 2.750" (69,85 mm) - Baureihe M4</b>		
		Flügelrad / geschlossener Magnet	PP	MS0145-0033-0200
			PP (Graphitlagerbuchse)	MS0145-0033-0300
			PVDF	MS0145-0039-0200
		Flügelrad / offener Magnet	PP	MS0145-0011-0100
			RTC	MS0145-0030-0100
		Flügelrad / geschlossener Magnet	AISI 316 SS (Graphitlagerbuchse)	MS0150-0114-0400
		<b>Flügelrad 2.875" (73,025 mm) - Baureihe M5</b>		
		Flügelrad / geschlossener Magnet	PP	MS0150-0098-0200
			PVDF	MS0150-0125-0200
			AISI 316 (Graphitlagerbuchse)	MS0150-0114-0400
		<b>Flügelrad 2.875" (73,025 mm) - Baureihe M5i</b>		
Flügelrad / geschlossener Magnet	PP	MS0150-0129-0200		
	PVDF	MS0150-0130-0200		
6	1	Rückgehäuse m. Axialscheibe (Keramik), 1/2" MPT	PP	MS0150-0031-0100
			PVDF	MS0150-0123-0100
			PPS	MS0150-0072-0100
			AISI 316 SS	MS0150-0110-0000
		Rückgehäuse m. Axialscheibe (Keramik), G 1" - AG	PP	MS1099-0003-0100
Rückgehäuse m. Axialscheibe (Keramik), 3/4" Schlauchanschluss	PP	MS0150-0159-0100		
7	1	Antriebsmagnet 9 mm gebohrt	PP/FE	MS0145-0054-0100
8	1	Motoradapter Serie 4 / 5 / 5i	PE	MU-0001-051-UK
			Aluminium	DT0001-0003-0002

**OPTIONALE PUMPENANSCHLÜSSE, SCHRAUBEN UND SONSTIGE NORMTEILE**

POS	STÜCK	BESCHREIBUNG	MATERIAL	ARTIKELNR.
10.1	7	Gehäuseschraube	A2	DT-DIN912-M4x40-A2
10.2		Unterlegscheibe	A2	DT-DIN9021A-4,3-3d-A2
11.1	4	Motoradapterschraube	A2	DT-DIN7985-M5x16-A2
11.2		Fächerscheibe	A2	DT-DIN6798AZ-5,3-A2
20	1	Bundbuchse DN 25 - G 1" A	PP	DT-BB-DN25-AG-PP
			PVDF	DT-BB-DN25-AG-PVDF
20	1	Einschraubteil DN25, d32 (G1 1/2" AG)	PP	DT-ET-DN25-AG-PP
			PVDF	DT-ET-DN25-AG-PVDF
21	1	O-Ring 32 x 3,5 mm	FKM	DT-OR-32x3,5-FKM75
22	1	Losflansch DN 25	EPDM	DT-OR-32x3,5-EPDM
23	1	Bundbuchse DN 15 - G 1/2" I	PVC	DT-LF-DN25-PVC
			PP	DT-BB-DN15-IG-PP
23	1	Einschraubteil DN15, d20 (G1" AG)	PVDF	DT-BB-DN15-IG-PVDF
			PP	DT-ET-DN15-IG-PP
24	1	O-Ring 15,88 x 2,62 mm	PVDF	DT-ET-DN15-IG-PVDF
			FKM	DT-OR-15,88x2,62-FKM75
25	1	Losflansch DN 15	EPDM	DT-OR-15,88x2,62-EPDM
			PVC	DT-LF-DN15-PVC
30 (M4/M5)	1	Elektromotor-230V-90W-BG56-2-pol.-B34k	230V - 90W	MOT-AL-230-0090-056-2-34
		Elektromotor-400V-90W-BG56-2-pol.-B34k	400V - 90W	MOT-VE-400-0090-056-2-34
30 (M5i)	1	Elektromotor-230V-120W-BG56-2-pol.-B34k	230V - 90W	MOT-AL-230-0120-056-2-34
		Elektromotor-400V-120W-BG56-2-pol.-B34k	400V - 90W	MOT-VE-400-0120-056-2-34

Alle Angaben unverbindlich, technische Änderungen vorbehalten! Technical data not binding and subject to change!  
 Copyright MARCH PUMPEN GmbH 2015

		MARCH PUMPEN GmbH Rathenaustraße 2 D-35394 Gießen info@march-pumpen.com www.march-pumpen.com			
		Datum	Name	Stückliste Parts List Baureihe / Series M4 - M5 - M5i	
		Gezeichnet	17.08.2015 P.Stachon		
		Kontrolliert			
		Norm		Stückliste_M4_M5_M5i	
a	aktualisiert	15.02.2018	PL	1 A3	
Status	Änderungen	Datum	Name		